

931I SERIES

ARCHITECT'S AND ENGINEER'S SPECIFICATIONS*

The heating equipment shall include a ceiling mounted 931I electric automatic fan-forced heater suitable for large area heating as manufactured by Indeeco®. The heater shall be designed for ceiling surface, recess or T-Bar mounting. Heaters shall be cETLus Listed.

HEATER ASSEMBLY: The heater assembly, which fits in the back box, shall consist of a fan panel upon which is mounted all of the operational parts of the heater.

HEATING ELEMENT: The heating element shall be of the non-glowing design consisting of 80/20 NiCh resistance wire enclosed in a steel sheath to which plate fins are copper brazed. It shall be warrantied for 5 years.

FAN AND FAN MOTOR: The fan shall be five-bladed aluminum. The fan motor shall be totally enclosed.

FAN DELAY SWITCH: Fan control shall be of bi-metallic, snap-action type and shall activate fan after heating element reaches operating temperature. The fan shall continue to operate after the thermostat is satisfied and until the heating element is cool.

THERMAL CUTOUT: A thermal cutout shall be built into the system to shut off the heater in the event of overheating.

DISCONNECT SWITCH: A double-pole single throw disconnect switch shall be mounted on the back box for positive disconnect of power supply. It will be completely concealed behind the faceplate.

BACK BOX: The back box shall be designed for duty as a recessed rough-in box either masonry or frame installations, and is also used with the surface mounting frame in surface mounting installations. The back box shall be 20- gauge galvanized steel and shall contain knockouts through which power leads are brought.

FACEPLATE: The louvered faceplate shall be of 14-gauge cold-rolled steel, phosphatized, then electrostatically painted Navajo White by a powder coat process. A ¼-inch mesh screen shall be installed beneath the faceplate to deter the insertion of foreign objects. The face plate shall be secured to the heating unit with tamper-resistant screws.

THREE-PIECE DESIGN: The heater shall be made up of a back box, a heater assembly and a faceplate.

OPTIONS:

THERMOSTAT: The optional tamper-resistant thermostat shall be of the bi-metallic, snap-action type with enclosed contacts. It shall be completely concealed behind the faceplate to become tamper-resistant (FIT-FT1-Z or FIT-FFT2-Z).

LOW VOLTAGE TIME DELAY RELAYS: 24 volt and 120 volt low voltage time delay relays are available as optional equipment to control 208, 240 or 277 volt heaters (with an external supplied 24 or 120 volt control circuit) in conjunction with central energy control systems. The built-in thermostat can then be used as one of the thermostats in an automatic night set back operation (FIR-FR2-Z or FIR-FR12-Z).

LOW VOLTAGE

TRANSFORMER/RELAYS: (Primary or Secondary) Transformer/Relays shall be available as optional equipment to control 208, 240 or 277 volt heaters (with single point supply connection and internal supplied 24 volt control circuit) in conjunction with central energy control systems. The built-in thermostat can then be used as one of the thermostats in an automatic night set back operation (FIR-FTR4-Z OR FIR-FTR7-Z).

SURFACE MOUNTING FRAME: The surface mounting frame, designed to allow full surface mounting, shall be of 14-gauge cold-rolled steel, phosphatized, then electrostatically painted by a powder coat process (FIF-FSM-N).

T-BAR FRAME: For T-Bar mounting, a 14-gauge cold-rolled steel frame, phosphatized and electrostatically painted by a powder coat process, shall be available. Frame shall be designed to mount in a standard 2' x 2' ceiling grid (FIF-FTBF-N).

**Indeeco reserves the right to change specifications without prior notice.*

Models & Specifications:

CATALOG NO.	ELECTRICAL DATA					SHIP WT.
	VOLTS	PHASE	WATTS	AMPS	BTU/HR	
9311F-F1500-N	120	1	1500	12.5	5120	23 lbs
9311F-F3007-N	277	1	3000/1500	10.8/5.4	10239/5120	23 lbs
9311F-F4008-N	208	1	4000/2000	19.2/9.8	13652/6826	23 lbs
9311F-F4004-N	240	1	4000/2000	16.7/14.4	13652/10239	23 lbs
	208	1	3000/1500		10239/5120	
9311F-F4007-N	277	1	4000/2000	14.4/12.5	13652/10239	23 lbs
	240	1	3000/1500		10239/5120	
9311F-F4804-N	240/208	1	4800/3600	20.0/17.3	16382/12287	23 lbs
9311F-F4807-N	277/240	1	4800/3600	17.3/15.0	16382/12287	23 lbs
9311F-F48483-N	480	3	4800	5.8	16382	23 lbs
9311F-F48483L-N	480	3	4800	5.8	16382	23 lbs
9311F-F3003-N	347	3	3000	8.6	10239	23 lbs
EFF3006	600	3	3000	5	10239	23 lbs
9311F-F4003-N	347	3	4000	11.5	13652	23 lbs
9311F-F4006-N	600	3	4000	6.7	13652	23 lbs
9311F-F4803-N	347	3	4800	13.8	16382	23 lbs
9311F-F4806-N	600	3	4800	8	16382	23 lbs

NOTE: Factory-wired for highest wattage, field-convertible to lower wattages. Orders above 7500' sea level require special order

Optional Accessories:

CATALOG NO.	DESCRIPTION	SHIP WT.
FIF-FSM-N	Surface Mounting Sleeve - Navajo White	6 lbs
FIR-FR2-Z (24V)	Time delay relay, 45-60 seconds to close when energized; Uses remote 24V or 120V power source	1 lbs
FIR-FR12-Z (120V)		
FIF-FTBF-N	T-Bar Frame Kit	4.5 lbs
FIT-FT1-Z	Single Pole T-Stat. (Field Installed)	1 lbs
FIT-FFT2-Z	Double Pole Thermostat. (Field Installed)	2 lbs
FIR-FTR4-Z	208/240V Primary Transformer 24V Relay	1 lbs
FIR-FTR7-Z	277V Primary 24V Sec. Transformer Relay	1 lbs

Dimensions and Clearances:

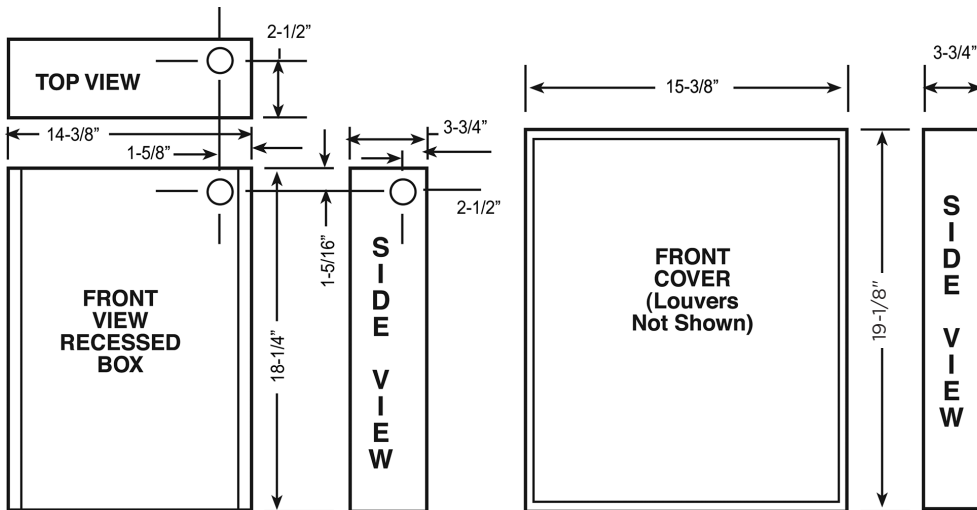

No matter the industry or application, Indeeco has a robust portfolio of innovative, reliable, high-performance comfort heating and ventilation solutions for all your heating needs.