

# Flange Heaters

## Construction Features

- Removable NEMA 1 outlet boxes provide free access to line terminals.
- Element spacers prevent hot spots.
- Permanent bus bars prevent loose connections.
- CSA approval available on most items.
- Raised face flanges insure leak-tight union with mating flange.
- Lifting rings afford ease of handling.
- Large diameter elements provide extra electrical insulation for better dielectric strength.

## Field Wire and Knockout Sizing

Table II

Number of Three-Phase Circuits					Field Wire Gauge	Number Of Circuits (Three-Phase)	Maximum Outlet Box Temperature (°F)			
5	4	3	2	1			158	320	392	
Trade Size Conduit Required (Inches)							Wire Insulation Rating (°C)			
							90	200	250	
					Maximum Amps Per Three-Phase Circuit					
1-1/4	1	1	3/4	1/2	14*	1	12	18	19.1	
						2		14.4	15.2	
						3		12.6	13.3	
						4-5		9	9.5	
1-1/4	1	1	3/4	1/2	12*	1	16	22.5	26.4	
						2		18	21.1	
						3		15.7	18.5	
						4-5		—	11.2	13.2
1-1/2	1-1/2	1-1/4	1	3/4	10*	1	23.2	30	35.7	
						2		18.5	24	28.6
						3		16.2	21	25
						4-5		—	15	17.8
2	2	2	1-1/2	1	8	1	31.9	41.5	45.5	
						2		25.5	33.2	36.4
						3		22.3	29	31.9
						4-5		15.9	20.7	22.7
2-1/2	2	2	1-1/2	1-1/4	6	1	43.5	55	57.3	
						2		34.8	44	45.8
						3		30.4	38.5	40.1
						4-5		21.7	27.5	28.6
3	2-1/2	2-1/2	2	1-1/4	4	1	55.1	62.5	72.5	
						2		44	50	58
						3		38.5	43.7	50.7
						4-5		27.5	31.2	36.2
3	3	2-1/2	2	1-1/2	3	1	63.8	76	81.3	
						2		51	60.8	65
						3		44.6	53.2	56.9
						4-5		31.9	38	40.6
Consult Factory	3	2-1/2	2	1-1/2	2	1	75.4	85.5	93.5	
						2		60.3	68.4	74.8
						3		52.7	59.8	65.5
						4-5		37.7	42.7	46.7
Consult Factory	Consult Factory	3	2-1/2	2	1	1	87	98.5	105.3	
						2		69.6	78.8	84.2
						3		60.9	68.9	73.7
						4-5		43.5	—	—

Values per NEC 2005 Article 310.

Conduit sizing is based on largest wire insulation thickness for temperature ratings shown.

Consult factory for wire sizes above 1 gauge or if required amps per circuit is above listed values.

\*Wire gauges 14, 12 and 10 are sized based on maximum fuse size per NEC Article 240-3.

# Flange Heaters

## Construction Features (continued)

**Outlet Boxes** - Removable NEMA 1 outlet boxes are furnished on heaters with 3" through 8" flanges, drawing up to 150 amps. A permanently mounted plate contains electrical knockouts.

On heaters with 10" and 12" flanges, or heaters drawing more than 150 amps, permanently attached NEMA 1 outlet boxes with threaded hubs are provided.

**Element Spacers** - Element spacers are fabricated from material similar to the element sheath and are normally perforated to allow for maximum fluid flow parallel to the elements. They prevent hot spots caused by elements touching while maintaining the size and rigidity of the heater bundle.

Spacers are provided on 24" maximum centers and are secured in such a manner as to allow elements to expand and contract freely.

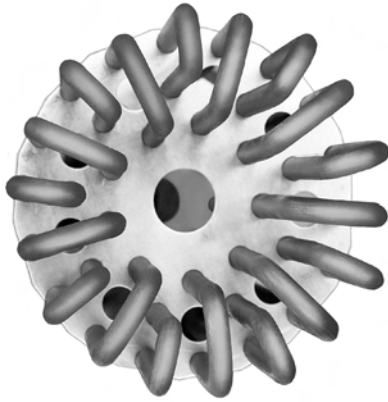

**Flanges** - Raised face flanges carry a nominal Class 150 rating and are made from forged steel or mill certified steel plate to ANSI standards. Raised face insures a leak-tight gasketed union with mating flange.

**Electrical Connections** - Pipe flange heaters are furnished with properly sized terminals and conduit openings to match the heater load, number of circuits and operating temperature. Table II shows the maximum amperage per circuit for various gauges of field wiring brought to heaters having one through five circuits. Note: The maximum conduit size is 3".

Unless otherwise specified, heaters are furnished with conduit openings and terminals suitable for a maximum outlet box temperature of 250° F and the number of circuits shown in the table. Heaters ordered with additional circuits, or for higher fluid temperatures, will be furnished with conduit openings and terminals to accommodate the wire gauges shown in Table II.

For three-phase conduits, amperage per circuit is calculated as follows:

$$\frac{\text{Total Heater KW} \times 1000}{\text{Line Voltage} \times \text{No. of Circuits} \times 1.73}$$

Occasionally low KW heaters operate from single-phase power. In this case, omit the 1.73 factor in the above formula.

When a heater has more than five circuits, or requires field wiring that will not fit into a single 3" conduit, multiple conduit openings will be furnished. For example, a heater with outlet box temperatures of 350° F with six circuits drawing 70 amps each would be furnished with two openings, each sized for 3" conduit. At 70 amps, 250° C insulated 1 gauge field wiring is required for three circuits per conduit.

**Gasketing** - A 1/16" thick gasket is furnished as standard with each heater. The gasket is sized to match the seating surface on the flange. Spirotallic gaskets are also available.

**Flange Temperature/Pressure Ratings** - Although pipe flanges have nominal ratings, the actual pressure that they will safely withstand is a function of temperature. Table III below shows pressure ratings per ANSI Standard B16.5.

## Flange Pressure Ratings (PSI)

Table III

Maximum Fluid Temperature °F	Class 150 Steel Flange (Standard)	Class 300 Steel Flange	Class 150 Type 304 SS Flange
-20 to 100	285	740	275
200	260	675	235
300	260	655	205
400	200	635	180
500	170	600	170
600	140	550	140
650	125	535	125
700	110	535	110
750	95	505	95
800	80	410	80
850	65*	270*	65
900	50*	170*	50
950	35*	105*	35
1000	20*	50*	20

\*These ratings are permissible, but not recommended. Type 304 stainless is preferred above 800° F.

# Flange Heaters

## Construction Features (continued)

**Bus Bars** - Stainless steel bus bars are permanently welded in place to eliminate field failures due to loose bus connections. Copper bus bars are used with lower temperature heaters and where amperage is high.



**Large Diameter Elements** - Elements measure .475" O.D., providing extra electrical insulation for superior dielectric strength. As a result, elements are suitable for line voltages up to 600 volts. At the same time, uniform heat transfer from coil to sheath is assured by compacting the insulation in high pressure rollers, then repressing all bends to insure insulation integrity in this critical area. Copper sheathed elements are silver soldered to the flange; all other materials are welded.

**Unheated Lengths** - It is imperative that the entire heated length of an element be submerged in liquid to prevent the sheath from overheating. Normally, copper, steel and stainless steel sheathed heaters have a 2" minimum cold end (unheated length). Incoloy sheathed heaters have a 5" minimum cold end.

Vertically mounted heaters require a longer cold end in applications where the liquid may not otherwise cover the elements.

**Terminal Seals** - Moisture-resistant epoxy seals are furnished as standard on all copper sheathed heaters operating in maximum fluid temperatures of 250° F.

Since steel, stainless steel and Incoloy sheathed heaters may operate at higher temperatures, standard units in these materials are furnished with mica terminal insulators and without epoxy seals.

When specified, and within temperature limits, epoxy seals are available with steel, stainless steel and Incoloy sheaths.

For applications requiring an absolute seal against moisture, ceramic-to-metal hermetic seals are available for temperatures up to 1000° F.

**Lifting Rings** - Lifting rings are provided on all heaters with flanges 4" and larger to facilitate handling.

**Circuiting** - All standard heaters are designed with electrical connections for a maximum outlet box temperature of 250° F with one electrical circuit for single stage operation unless two or more circuits are specified in the listing tables.

Additional circuits are available upon request.

Three-phase circuits are always balanced using a multiple of three elements per circuit.

# Flange Heaters

## Construction Features (continued)

### Dimensions of Class 150 ANSI Flange Heaters

Nominal flange size (inches)	Flange diameter (inches)	Flange thickness (inches)	Bolt circle (inches)	Bolt hole diameter (inches)	Bolt diameter (inches)	Number of bolts
2	6	3/4	4-3/4	3/4	5/8	4
3	7-1/2	15/16	6	3/4	5/8	4
4	9	15/16	7-1/2	3/4	5/8	8
5	10	15/16	8-1/2	7/8	3/4	8
6	11	1	9-1/2	7/8	3/4	8
8	13-1/2	1-1/8	11-3/4	7/8	3/4	8
10	16	1-3/16	14-1/4	1	7/8	12
12	19	1-1/4	17	1	7/8	12
14	21	1-3/8	18-3/4	1-1/8	1	12
16	23-1/2	1-4/9	21-1/4	1-1/8	1	16
18	25	1-9/16	22-3/4	1-1/8	1-1/8	16

### Dimensions of Class 300 ANSI Flange Heaters

Nominal flange size (inches)	Flange diameter (inches)	Flange thickness (inches)	Bolt circle (inches)	Bolt hole diameter (inches)	Bolt diameter (inches)	Number of bolts
2	6-1/2	7/8	5	3/4	5/8	8
3	8-1/4	1-1/8	6-5/8	7/8	3/4	8
4	10	1-1/4	7-7/8	7/8	3/4	8
5	11	1-3/8	9-1/4	7/8	3/4	8
6	12-1/2	1-7/16	10-5/8	7/8	3/4	12
8	15	1-5/8	13	1	7/8	12
10	17-1/2	1-7/8	15-1/4	1-1/8	1	16
12	20-1/2	2	17-3/4	1-1/4	1-1/8	16
14	23	2-1/8	20-1/4	1-1/4	1-1/8	20
16	25-1/2	2-1/4	22-1/5	1-3/8	1-1/4	20
18	28	2-3/8	24-3/4	1-3/8	1-1/4	24

### Height of Terminal Boxes

Nominal flange size (inches)	Flange diameter (inches)	Flange thickness (inches)	Bolt circle (inches)	Bolt hole diameter (inches)	Bolt diameter (inches)	Number of bolts
2	4-3/8	8-1/2	4-3/8	8-1/2	6	9-1/2
3	4-3/8	9-3/4	5-1/4	9-1/2	6	10-1/2
4	4-3/8	9	5-1/4	8-1/4	6	9
5	5	9	5-1/4	8-1/4	6	9
6	5	9	5-1/4	8-1/4	6	9
8	6	10	5-1/4	8-1/4	10	10
10	8-1/4	8-1/4	8-1/4	8-1/4	10	10
12	8-1/4	8-1/4	8-1/4	8-1/4	Consult Factory	Consult Factory

# Flange Heaters

## Water Heaters

### Copper Sheath, Steel Flange

50 W/Sq. In.

Flange Size (Inches)	Number of Elements	KW	NEMA 1 Terminal Box							
			B Dimensions (Inches)	Catalog Number	Availability					
					1 Phase			3 Phase		
					208V	240V	480V	208V	240V	480V
3	3	4.5	12-3/4	721N0321	•	•	•	•	•	•
		6	16	721N0521	•	•	•	•	•	•
		7.5	19-1/2	721N0721	•	•	•	•	•	•
		9	22-3/4	721N0921	•	•	•	•	•	•
		12	29-1/2	721N1121	•	•	•	•	•	•
		15	36-1/4	721N1221	•	•	•	•	•	•
		18	43	721N1321	•	•	•	•	•	•
		21	49-1/2	721N1421	•	•	•	•	•	•
		24	56-1/4	721N1521	•	•	•	•	•	•
		30	69-3/4	721N1621	•	•	•	•	•	•
5	6	9	13	722N0321	•	•	•	•	•	•
		12	16-1/4	722N0521	•	•	•	•	•	•
		15	19-3/4	722N0721	•	•	•	•	•	•
		18	23	722N0921	•	•	•	•	•	•
		24	29-3/4	722N1121	•	•	•	•	•	•
		30	36-1/2	722N1221	• <sup>2</sup>	• <sup>2</sup>	•	•	•	•
		36	43-1/4	722N1321	• <sup>2</sup>	• <sup>2</sup>	•	•	•	•
		42	49-3/4	722N1421	• <sup>2</sup>	• <sup>2</sup>	•	•	•	•
		48	56-1/2	722N1521	• <sup>2</sup>	• <sup>2</sup>	•	• <sup>2</sup>	•	•
		60	70	722N1721	•	•	• <sup>2</sup>	•	•	•
5	9	18	16-1/4	722N2221	•	•	•	•	•	•
		24	20-3/4	722N2521	•	•	•	•	•	•
		30	25-1/4	722N2721	• <sup>3</sup>	• <sup>3</sup>	•	•	•	•
		36	29-3/4	722N2821	• <sup>3</sup>	• <sup>3</sup>	•	•	•	•
		45	36-1/2	722N2921	• <sup>3</sup>	• <sup>3</sup>	•	• <sup>3</sup>	•	•
		54	43-1/4	722N3021	• <sup>3</sup>	• <sup>3</sup>	•	• <sup>3</sup>	• <sup>3</sup>	•
		63	49-3/4	722N3121	• <sup>3</sup>	• <sup>3</sup>	• <sup>3</sup>	• <sup>3</sup>	• <sup>3</sup>	•
		72	56-1/2	722N3221	• <sup>3</sup>	• <sup>3</sup>	• <sup>3</sup>	• <sup>3</sup>	• <sup>3</sup>	•
		90	70	722N3421	•	•	• <sup>3</sup>	•	•	•
		6	12	24	16-1/4	723N0521	•	•	•	•
30	19-1/2			723N0721	• <sup>2</sup>	• <sup>2</sup>	•	•	•	•
36	22-3/4			723N0921	• <sup>2</sup>	• <sup>2</sup>	•	•	•	•
48	31			723N1121	• <sup>3</sup>	• <sup>2</sup>	•	• <sup>2</sup>	•	•
60	36-1/4			723N1221	• <sup>3</sup>	• <sup>3</sup>	• <sup>2</sup>	• <sup>2</sup>	• <sup>2</sup>	•
72	43			723N1321	• <sup>4</sup>	• <sup>3</sup>	• <sup>2</sup>	• <sup>2</sup>	• <sup>2</sup>	•
84	49-3/4			723N1421	• <sup>4</sup>	• <sup>3</sup>	• <sup>2</sup>	• <sup>2</sup>	• <sup>2</sup>	•
96	56-1/4			723N1521	• <sup>4</sup>	• <sup>4</sup>	• <sup>2</sup>	• <sup>4</sup>	• <sup>2</sup>	•
108	63			723N1621	•	• <sup>4</sup>	• <sup>2</sup>	• <sup>4</sup>	• <sup>2</sup>	• <sup>2</sup>
120	69-3/4			723N1721	•	•	• <sup>3</sup>	•	•	• <sup>2</sup>

•<sup>2</sup>= Superscript indicates number of circuits.

Please specify volts, phase, circuits, terminal box rating and, if needed, thermostat range from options listed on page 27.

ANSI Flanges are available in larger sizes through 26".

Flange Size (Inches)	Number of Elements	KW	NEMA 1 Terminal Box							
			B Dimensions (Inches)	Catalog Number	Availability					
					1 Phase			3 Phase		
					208V	240V	480V	208V	240V	480V
6	15	40	20-3/4	723N2521	• <sup>3</sup>	• <sup>3</sup>	•	•	•	•
		50	25	723N2721	• <sup>3</sup>	• <sup>3</sup>	•	• <sup>5</sup>	• <sup>5</sup>	•
		60	29-1/2	723N2821	• <sup>3</sup>	• <sup>3</sup>	• <sup>3</sup>	• <sup>5</sup>	• <sup>5</sup>	•
		75	36-1/4	723N2921	• <sup>3</sup>	• <sup>3</sup>	• <sup>3</sup>	• <sup>5</sup>	• <sup>5</sup>	•
		90	43	723N3021	• <sup>3</sup>	• <sup>5</sup>	• <sup>3</sup>	• <sup>5</sup>	• <sup>5</sup>	•
		120	56	723N3221	•	• <sup>5</sup>	• <sup>3</sup>	• <sup>5</sup>	• <sup>5</sup>	• <sup>5</sup>
		135	63	723N3321	•	• <sup>5</sup>	• <sup>3</sup>	•	• <sup>5</sup>	• <sup>5</sup>
		150	69-3/4	723N3421	•	•	• <sup>3</sup>	•	•	• <sup>6</sup>
		8	18	36	16	724N0721	• <sup>2</sup>	• <sup>2</sup>	•	•
48	20-1/2			724N0821	• <sup>2</sup>	• <sup>2</sup>	•	• <sup>2</sup>	•	•
54	22-3/4			724N0921	• <sup>2</sup>	• <sup>2</sup>	•	• <sup>2</sup>	• <sup>2</sup>	•
60	25			724N1021	• <sup>3</sup>	• <sup>3</sup>	• <sup>2</sup>	• <sup>2</sup>	• <sup>2</sup>	•
72	29-1/2			724N1121	• <sup>3</sup>	• <sup>3</sup>	• <sup>2</sup>	• <sup>2</sup>	• <sup>2</sup>	•
90	36-1/4			724N1221	• <sup>6</sup>	• <sup>6</sup>	• <sup>2</sup>	• <sup>3</sup>	• <sup>2</sup>	•
108	42-7/8			724N1321	• <sup>6</sup>	• <sup>6</sup>	• <sup>2</sup>	• <sup>3</sup>	• <sup>3</sup>	• <sup>2</sup>
126	49-1/2			724N1421	• <sup>6</sup>	• <sup>6</sup>	• <sup>3</sup>	• <sup>3</sup>	• <sup>3</sup>	• <sup>2</sup>
144	56-1/4			724N1521	• <sup>6</sup>	• <sup>6</sup>	• <sup>3</sup>	• <sup>6</sup>	• <sup>3</sup>	• <sup>2</sup>
162	63			724N1621	•	• <sup>6</sup>	• <sup>3</sup>	•	• <sup>6</sup>	• <sup>2</sup>
180	69-3/4	724N1721	•	•	• <sup>6</sup>	•	•	• <sup>2</sup>		
8	27	72	20-1/2	724N2521	• <sup>3</sup>	• <sup>3</sup>	• <sup>3</sup>	• <sup>3</sup>	• <sup>3</sup>	•
		90	25	724N2721	• <sup>9</sup>	• <sup>9</sup>	• <sup>3</sup>	• <sup>3</sup>	• <sup>3</sup>	•
		108	29-1/2	724N2821	• <sup>9</sup>	• <sup>9</sup>	• <sup>3</sup>	• <sup>3</sup>	• <sup>3</sup>	• <sup>3</sup>
		135	36-1/4	724N2921	• <sup>9</sup>	• <sup>9</sup>	• <sup>3</sup>	• <sup>9</sup>	• <sup>3</sup>	• <sup>3</sup>
		162	43	724N3021	• <sup>9</sup>	• <sup>9</sup>	• <sup>3</sup>	• <sup>9</sup>	• <sup>9</sup>	• <sup>3</sup>
		189	49-1/2	724N3121	• <sup>9</sup>	• <sup>9</sup>	• <sup>9</sup>	• <sup>9</sup>	• <sup>9</sup>	• <sup>3</sup>
		216	56-1/4	724N3221	• <sup>9</sup>	• <sup>9</sup>	• <sup>9</sup>	• <sup>9</sup>	• <sup>9</sup>	• <sup>3</sup>
		243	63	724N3321	•	• <sup>9</sup>	• <sup>9</sup>	•	• <sup>9</sup>	• <sup>3</sup>
		270	69-3/4	724N3421	•	•	• <sup>9</sup>	•	•	• <sup>3</sup>
		10	36	72	16	725N0521	• <sup>3</sup>	• <sup>3</sup>	• <sup>2</sup>	• <sup>2</sup>
96	20-1/2			725N0721	• <sup>4</sup>	• <sup>4</sup>	• <sup>3</sup>	• <sup>3</sup>	• <sup>2</sup>	•
120	25			725N1021	• <sup>6</sup>	• <sup>6</sup>	• <sup>3</sup>	• <sup>3</sup>	• <sup>3</sup>	• <sup>2</sup>
144	29-1/2			725N1121	• <sup>6</sup>	• <sup>6</sup>	• <sup>3</sup>	• <sup>4</sup>	• <sup>3</sup>	• <sup>2</sup>
180	36-1/4			725N1221	• <sup>9</sup>	• <sup>9</sup>	• <sup>4</sup>	• <sup>6</sup>	• <sup>4</sup>	• <sup>2</sup>
216	43			725N1321	• <sup>9</sup>	• <sup>9</sup>	• <sup>4</sup>	• <sup>6</sup>	• <sup>6</sup>	• <sup>3</sup>
252	49-1/2			725N1421	• <sup>12</sup>	• <sup>9</sup>	• <sup>6</sup>	• <sup>6</sup>	• <sup>6</sup>	• <sup>3</sup>
288	56-1/4			725N1521	• <sup>12</sup>	• <sup>12</sup>	• <sup>6</sup>	• <sup>12</sup>	• <sup>6</sup>	• <sup>3</sup>
324	63			725N1621	•	• <sup>12</sup>	• <sup>6</sup>	•	• <sup>12</sup>	• <sup>4</sup>
360	69-3/4			725N1721	•	•	• <sup>9</sup>	•	•	• <sup>4</sup>
12	48	72	12-1/2	726N0421	• <sup>3</sup>	• <sup>3</sup>	• <sup>2</sup>	• <sup>2</sup>	• <sup>2</sup>	•
		96	16	726N0521	• <sup>4</sup>	• <sup>4</sup>	• <sup>2</sup>	• <sup>4</sup>	• <sup>2</sup>	•
		120	19-1/4	726N0621	• <sup>6</sup>	• <sup>6</sup>	• <sup>3</sup>	• <sup>4</sup>	• <sup>4</sup>	• <sup>2</sup>
		144	22-3/4	726N0921	• <sup>6</sup>	• <sup>6</sup>	• <sup>3</sup>	• <sup>4</sup>	• <sup>4</sup>	• <sup>2</sup>
		192	29-1/4	726N1121	• <sup>8</sup>	• <sup>8</sup>	• <sup>4</sup>	• <sup>8</sup>	• <sup>4</sup>	• <sup>2</sup>
		240	36	726N1221	• <sup>12</sup>	• <sup>12</sup>	• <sup>6</sup>	• <sup>8</sup>	• <sup>8</sup>	• <sup>4</sup>
		288	42-3/4	726N1321	• <sup>12</sup>	• <sup>12</sup>	• <sup>6</sup>	• <sup>8</sup>	• <sup>8</sup>	• <sup>4</sup>
		336	49-1/2	726N1421	•	• <sup>12</sup>	• <sup>6</sup>	• <sup>8</sup>	• <sup>8</sup>	• <sup>4</sup>
		384	56-1/4	726N1521	•	•	• <sup>8</sup>	• <sup>16</sup>	• <sup>8</sup>	• <sup>4</sup>
		432	63	726N1621	•	•	• <sup>8</sup>	•	• <sup>16</sup>	• <sup>8</sup>
480	69-1/2	726N1721	•	•	• <sup>12</sup>	•	•	• <sup>8</sup>		

# Flange Heaters

## Water Heaters

Type 304 SS Sheath, Steel Flange

50 W/Sq. In.

Flange Size (Inches)	Number of Elements	KW	NEMA 1 Terminal Box							
			B Dimensions (Inches)	Catalog Number	Availability					
					1 Phase			3 Phase		
					208V	240V	480V	208V	240V	480V
3	3	4.5	12-1/4	721N0201	•	•	•	•	•	•
		6	15-3/4	721N0301	•	•	•	•	•	•
		7.5	19	721N0401	•	•	•	•	•	•
		9	22-1/2	721N0501	•	•	•	•	•	•
		12	29-1/4	721N0601	•	•	•	•	•	•
		15	35-1/4	721N0701	•	•	•	•	•	•
		18	42-1/2	721N0801	•	•	•	•	•	•
		24	56	721N0901	•	•	•	•	•	•
		30	69-1/4	721N1001	•	•	•	•	•	•
		5	6	9	12-1/2	722N0201	•	•	•	•
12	16			722N0301	•	•	•	•	•	•
15	19-1/4			722N0401	•	•	•	•	•	•
18	22-3/4			722N0501	•	•	•	•	•	•
24	29-1/4			722N0601	• <sup>2</sup>	• <sup>2</sup>	•	•	•	•
30	36			722N0701	• <sup>2</sup>	• <sup>2</sup>	•	•	•	•
36	42-3/4			722N0801	• <sup>2</sup>	• <sup>2</sup>	•	•	•	•
48	56-1/4			722N0901	• <sup>3</sup>	• <sup>3</sup>	•	• <sup>2</sup>	•	•
60	69-1/2			722N1001	•	•	• <sup>2</sup>	•	•	•
5	9			18	16	722N1101	•	•	•	•
		22.5	19-1/4	722N1201	•	•	•	•	•	•
		27	22-3/4	722N1301	• <sup>3</sup>	•	•	•	•	•
		36	29-1/4	722N1401	• <sup>3</sup>	• <sup>3</sup>	•	•	•	•
		45	36	722N1501	• <sup>3</sup>	• <sup>3</sup>	•	• <sup>3</sup>	•	•
		54	42-3/4	722N1601	• <sup>3</sup>	• <sup>3</sup>	•	• <sup>3</sup>	• <sup>3</sup>	•
		72	56-1/4	722N1701	• <sup>3</sup>	• <sup>3</sup>	• <sup>3</sup>	• <sup>3</sup>	• <sup>3</sup>	•
6	12	24	15-3/4	723N0301	•	•	•	•	•	•
		30	19-1/4	723N0401	• <sup>2</sup>	• <sup>2</sup>	•	•	•	•
		36	22-1/2	723N0501	• <sup>2</sup>	• <sup>2</sup>	•	•	•	•
		48	29-1/4	723N0601	• <sup>2</sup>	• <sup>2</sup>	•	• <sup>2</sup>	•	•
		60	36	723N0701	• <sup>3</sup>	• <sup>3</sup>	• <sup>2</sup>	• <sup>2</sup>	• <sup>2</sup>	•
		72	42-3/4	723N0801	• <sup>3</sup>	• <sup>3</sup>	• <sup>2</sup>	• <sup>2</sup>	• <sup>2</sup>	•
		96	56	723N0901	• <sup>4</sup>	• <sup>4</sup>	• <sup>2</sup>	• <sup>4</sup>	• <sup>2</sup>	•
		120	69-1/2	723N1001	•	•	• <sup>3</sup>	•	•	• <sup>2</sup>

•<sup>2</sup>= Superscript indicates number of circuits.

Please specify volts, phase, circuits, terminal box rating and, if needed, thermostat range from options listed on page 27.

ANSI Flanges are available in larger sizes through 26".

Flange Size (Inches)	Number of Elements	KW	NEMA 1 Terminal Box									
			B Dimensions (Inches)	Catalog Number	Availability							
					1 Phase			3 Phase				
					208V	240V	480V	208V	240V	480V		
6	15	30	15-3/4	723N1101	• <sup>3</sup>	• <sup>3</sup>	•	•	•	•		
		37.5	19-1/4	723N1201	• <sup>3</sup>	• <sup>3</sup>	•	•	•	•		
		45	22-1/2	723N1301	• <sup>3</sup>	• <sup>3</sup>	•	•	•	•		
		60	29-1/4	723N1401	• <sup>3</sup>	• <sup>3</sup>	• <sup>3</sup>	• <sup>5</sup>	•	•		
		75	36	723N1501	• <sup>5</sup>	• <sup>5</sup>	• <sup>3</sup>	• <sup>5</sup>	• <sup>5</sup>	•		
		90	42-3/4	723N1601	• <sup>5</sup>	• <sup>5</sup>	• <sup>3</sup>	• <sup>5</sup>	• <sup>5</sup>	•		
		120	56	723N1701	•	•	• <sup>3</sup>	• <sup>5</sup>	• <sup>5</sup>	• <sup>5</sup>		
		150	69-1/2	723N1801	•	•	• <sup>3</sup>	• <sup>5</sup>	• <sup>5</sup>	• <sup>5</sup>		
		8	18	36	15-3/4	724N0301	• <sup>2</sup>	• <sup>2</sup>	•	•	•	•
				45	19	724N0401	• <sup>2</sup>	• <sup>2</sup>	•	• <sup>2</sup>	•	•
54	22-1/2			724N0501	• <sup>3</sup>	• <sup>3</sup>	•	• <sup>2</sup>	• <sup>2</sup>	•		
72	29-1/4			724N0601	• <sup>3</sup>	• <sup>3</sup>	• <sup>2</sup>	• <sup>2</sup>	• <sup>2</sup>	•		
90	35-3/4			724N0701	• <sup>6</sup>	• <sup>6</sup>	• <sup>2</sup>	• <sup>3</sup>	• <sup>2</sup>	•		
108	42-1/2			724N0801	• <sup>6</sup>	• <sup>6</sup>	• <sup>2</sup>	• <sup>3</sup>	• <sup>3</sup>	• <sup>2</sup>		
144	56			724N0901	• <sup>6</sup>	• <sup>6</sup>	• <sup>3</sup>	• <sup>6</sup>	• <sup>3</sup>	• <sup>2</sup>		
180	69-1/2			724N1001	•	•	• <sup>6</sup>	•	•	• <sup>2</sup>		
8	27			54	15-3/4	724N1101	• <sup>3</sup>	• <sup>3</sup>	•	• <sup>3</sup>	• <sup>3</sup>	•
				67.5	19	724N1201	• <sup>3</sup>	• <sup>3</sup>	• <sup>3</sup>	• <sup>3</sup>	• <sup>3</sup>	•
		81	22-1/2	724N1301	• <sup>3</sup>	• <sup>3</sup>	• <sup>3</sup>	• <sup>3</sup>	• <sup>3</sup>	•		
		108	29-1/4	724N1401	• <sup>9</sup>	• <sup>9</sup>	• <sup>3</sup>	• <sup>3</sup>	• <sup>3</sup>	• <sup>3</sup>		
		135	35-3/4	724N1501	• <sup>9</sup>	• <sup>9</sup>	• <sup>3</sup>	• <sup>9</sup>	• <sup>9</sup>	• <sup>3</sup>		
		162	42-1/2	724N1601	• <sup>9</sup>	• <sup>9</sup>	• <sup>3</sup>	• <sup>9</sup>	• <sup>9</sup>	• <sup>3</sup>		
		216	56	724N1701	• <sup>9</sup>	• <sup>9</sup>	• <sup>9</sup>	• <sup>9</sup>	• <sup>9</sup>	• <sup>3</sup>		
10	36	54	12-1/4	725N0201	• <sup>3</sup>	• <sup>3</sup>	•	• <sup>2</sup>	• <sup>2</sup>	•		
		72	15-3/4	725N0301	• <sup>3</sup>	• <sup>3</sup>	•	• <sup>2</sup>	• <sup>2</sup>	•		
		90	19	725N0401	• <sup>4</sup>	• <sup>4</sup>	•	• <sup>3</sup>	• <sup>2</sup>	•		
		108	22-1/2	725N0501	• <sup>6</sup>	• <sup>6</sup>	• <sup>2</sup>	• <sup>3</sup>	• <sup>3</sup>	• <sup>2</sup>		
		144	29-1/4	725N0601	• <sup>6</sup>	• <sup>6</sup>	• <sup>2</sup>	• <sup>4</sup>	• <sup>3</sup>	• <sup>2</sup>		
		180	35-3/4	725N0701	• <sup>9</sup>	• <sup>9</sup>	• <sup>2</sup>	• <sup>6</sup>	• <sup>4</sup>	• <sup>2</sup>		
		216	42-1/2	725N0801	• <sup>9</sup>	• <sup>9</sup>	• <sup>3</sup>	• <sup>6</sup>	• <sup>6</sup>	• <sup>3</sup>		
		288	56	725N0901	• <sup>12</sup>	• <sup>12</sup>	• <sup>3</sup>	• <sup>12</sup>	• <sup>6</sup>	• <sup>3</sup>		
		360	69-1/2	725N1001	•	•	• <sup>4</sup>	•	•	• <sup>4</sup>		
		12	48	72	12-1/4	726N0201	• <sup>3</sup>	• <sup>3</sup>	• <sup>2</sup>	• <sup>2</sup>	• <sup>2</sup>	•
96	15-1/2			726N0301	• <sup>4</sup>	• <sup>4</sup>	• <sup>2</sup>	• <sup>4</sup>	• <sup>2</sup>	•		
120	19			726N0401	• <sup>6</sup>	• <sup>6</sup>	• <sup>3</sup>	• <sup>4</sup>	• <sup>4</sup>	• <sup>2</sup>		
144	22-1/4			726N0501	• <sup>6</sup>	• <sup>6</sup>	• <sup>3</sup>	• <sup>4</sup>	• <sup>4</sup>	• <sup>2</sup>		
192	29			726N0601	• <sup>8</sup>	• <sup>8</sup>	• <sup>4</sup>	• <sup>8</sup>	• <sup>4</sup>	• <sup>2</sup>		
240	35-3/4			726N0701	• <sup>12</sup>	• <sup>12</sup>	• <sup>6</sup>	• <sup>8</sup>	• <sup>8</sup>	• <sup>4</sup>		
288	42-1/2			726N0801	• <sup>12</sup>	• <sup>12</sup>	• <sup>6</sup>	• <sup>8</sup>	• <sup>8</sup>	• <sup>4</sup>		
384	56			726N0901	•	•	• <sup>8</sup>	• <sup>12</sup>	• <sup>8</sup>	• <sup>4</sup>		
480	69-1/4			726N1001	•	•	• <sup>12</sup>	•	•	• <sup>8</sup>		

# Flange Heaters

## Water Heaters

Incoloy 800 Sheath, Steel Flange

50 W/Sq. In.

Flange Size (Inches)	Number of Elements	KW	NEMA 1 Terminal Box							
			B Dimensions (Inches)	Catalog Number	Availability					
					1 Phase			3 Phase		
					208V	240V	480V	208V	240V	480V
3	3	4.5	15-1/4	721N0281	•	•	•	•	•	•
		6	18-3/4	721N0381	•	•	•	•	•	•
		7.5	22	721N0481	•	•	•	•	•	•
		9	25-1/2	721N0581	•	•	•	•	•	•
		12	32-1/4	721N0681	•	•	•	•	•	•
		15	38-3/4	721N0781	•	•	•	•	•	•
		18	45-1/2	721N0881	•	•	•	•	•	•
		24	59	721N0981	•	•	•	•	•	•
		30	72-1/4	721N1081			•			•
		5	6	9	15-1/2	722N0281	•	•	•	•
12	19			722N0381	•	•	•	•	•	•
15	22-1/4			722N0481	•	•	•	•	•	•
18	25-3/4			722N0581	•	•	•	•	•	•
24	32-1/4			722N0681	• <sup>2</sup>	• <sup>2</sup>	•	•	•	•
30	39			722N0781	• <sup>2</sup>	• <sup>2</sup>	•	•	•	•
36	45-3/4			722N0881	• <sup>2</sup>	• <sup>2</sup>	•	•	•	•
48	59-1/4			722N0981	• <sup>3</sup>	• <sup>3</sup>	•	• <sup>2</sup>	•	•
60	72-1/4			722N1081			• <sup>2</sup>			•
5	9			18	19	722N1181	•	•	•	•
		22.5	22-1/4	722N1281	•	•	•	•	•	•
		27	28-3/4	722N1381	• <sup>3</sup>	•	•	•	•	•
		36	32-1/4	722N1481	• <sup>3</sup>	• <sup>3</sup>	•	•	•	•
		45	39	722N1581	• <sup>3</sup>	• <sup>3</sup>	•	• <sup>3</sup>	•	•
		54	45-3/4	722N1681	• <sup>3</sup>	• <sup>3</sup>	•	• <sup>3</sup>	• <sup>3</sup>	•
		72	59-1/4	722N1781	• <sup>3</sup>	• <sup>3</sup>	• <sup>3</sup>	• <sup>3</sup>	• <sup>3</sup>	•
6	12	24	18-3/4	723N0381	•	•	•	•	•	•
		30	22-1/4	723N0481	• <sup>2</sup>	• <sup>2</sup>	•	•	•	•
		36	25-1/2	723N0581	• <sup>2</sup>	• <sup>2</sup>	•	•	•	•
		48	32-1/4	723N0681	• <sup>2</sup>	• <sup>2</sup>	•	• <sup>2</sup>	•	•
		60	39	723N0781	• <sup>3</sup>	• <sup>3</sup>	• <sup>2</sup>	• <sup>2</sup>	• <sup>2</sup>	•
		72	45-3/4	723N0881	• <sup>3</sup>	• <sup>3</sup>	• <sup>2</sup>	• <sup>2</sup>	• <sup>2</sup>	•
		96	59	723N0981	• <sup>4</sup>	• <sup>4</sup>	• <sup>2</sup>	• <sup>4</sup>	• <sup>2</sup>	•
		120	72-1/2	723N1081			• <sup>3</sup>			• <sup>2</sup>

•<sup>2</sup>= Superscript indicates number of circuits.

Please specify volts, phase, circuits, terminal box rating and, if needed, thermostat range from options listed on page 27.

ANSI Flanges are available in larger sizes through 26".

Flange Size (Inches)	Number of Elements	KW	NEMA 1 Terminal Box							
			B Dimensions (Inches)	Catalog Number	Availability					
					1 Phase			3 Phase		
					208V	240V	480V	208V	240V	480V
6	15	30	18-3/4	723N1181	• <sup>3</sup>	• <sup>3</sup>	•	•	•	•
		37.5	22-1/4	723N1281	• <sup>3</sup>	• <sup>3</sup>	•	•	•	•
		45	25-1/2	723N1381	• <sup>3</sup>	• <sup>3</sup>	•	• <sup>5</sup>	•	•
		60	32-1/4	723N1481	• <sup>3</sup>	• <sup>3</sup>	• <sup>3</sup>	• <sup>5</sup>	• <sup>5</sup>	•
		75	39	723N1581	• <sup>5</sup>	• <sup>5</sup>	• <sup>3</sup>	• <sup>5</sup>	• <sup>5</sup>	•
		90	45-3/4	723N1681	• <sup>5</sup>	• <sup>5</sup>	• <sup>3</sup>	• <sup>5</sup>	• <sup>5</sup>	•
		120	59	723N1781			• <sup>3</sup>	• <sup>5</sup>	• <sup>5</sup>	• <sup>5</sup>
		150	72-1/2	723N1881			• <sup>3</sup>			• <sup>5</sup>
		8	18	36	18-1/4	724N0381	• <sup>2</sup>	• <sup>2</sup>	•	•
45	22			724N0481	• <sup>2</sup>	• <sup>2</sup>	•	•	•	•
54	25-1/2			724N0581	• <sup>3</sup>	• <sup>3</sup>	•	• <sup>2</sup>	• <sup>2</sup>	•
72	32-1/4			724N0681	• <sup>3</sup>	• <sup>3</sup>	• <sup>2</sup>	• <sup>2</sup>	• <sup>2</sup>	•
90	38-3/4			724N0781	• <sup>6</sup>	• <sup>6</sup>	• <sup>2</sup>	• <sup>3</sup>	• <sup>2</sup>	•
108	45-1/2			724N0881	• <sup>6</sup>	• <sup>6</sup>	• <sup>2</sup>	• <sup>3</sup>	• <sup>3</sup>	• <sup>2</sup>
144	59			724N0981	• <sup>6</sup>	• <sup>6</sup>	• <sup>3</sup>	• <sup>6</sup>	• <sup>3</sup>	• <sup>2</sup>
180	72-1/2			724N1081			• <sup>6</sup>			• <sup>2</sup>
8	27	54	18-1/4	724N1181	• <sup>3</sup>	• <sup>3</sup>	•	• <sup>3</sup>	• <sup>3</sup>	•
		67.5	22	724N1281	• <sup>3</sup>	• <sup>3</sup>	• <sup>3</sup>	• <sup>3</sup>	• <sup>3</sup>	•
		81	25-1/2	724N1381	• <sup>9</sup>	• <sup>9</sup>	• <sup>3</sup>	• <sup>3</sup>	• <sup>3</sup>	•
		108	32-1/4	724N1481	• <sup>9</sup>	• <sup>9</sup>	• <sup>3</sup>	• <sup>3</sup>	• <sup>3</sup>	• <sup>3</sup>
		135	38-3/4	724N1581	• <sup>9</sup>	• <sup>9</sup>	• <sup>3</sup>	• <sup>9</sup>	• <sup>3</sup>	• <sup>3</sup>
		162	45-1/2	724N1681	• <sup>9</sup>	• <sup>9</sup>	• <sup>3</sup>	• <sup>9</sup>	• <sup>3</sup>	• <sup>3</sup>
		216	59	724N1781	• <sup>9</sup>	• <sup>9</sup>	• <sup>9</sup>	• <sup>9</sup>	• <sup>9</sup>	• <sup>3</sup>
270	72-1/2	724N1881			• <sup>9</sup>			• <sup>3</sup>		
10	36	54	15-1/4	725N0281	• <sup>3</sup>	• <sup>3</sup>	•	• <sup>2</sup>	• <sup>2</sup>	•
		72	18-1/4	725N0381	• <sup>3</sup>	• <sup>3</sup>	•	• <sup>2</sup>	• <sup>2</sup>	•
		90	22	725N0481	• <sup>4</sup>	• <sup>4</sup>	•	• <sup>2</sup>	• <sup>2</sup>	•
		108	25-1/2	725N0581	• <sup>6</sup>	• <sup>6</sup>	• <sup>2</sup>	• <sup>3</sup>	• <sup>3</sup>	• <sup>2</sup>
		144	32-1/4	725N0681	• <sup>6</sup>	• <sup>6</sup>	• <sup>2</sup>	• <sup>4</sup>	• <sup>3</sup>	• <sup>2</sup>
		180	38-3/4	725N0781	• <sup>9</sup>	• <sup>9</sup>	• <sup>2</sup>	• <sup>6</sup>	• <sup>4</sup>	• <sup>2</sup>
		216	45-1/2	725N0881	• <sup>9</sup>	• <sup>9</sup>	• <sup>3</sup>	• <sup>6</sup>	• <sup>6</sup>	• <sup>3</sup>
		288	59	725N0981	• <sup>12</sup>	• <sup>12</sup>	• <sup>3</sup>	• <sup>12</sup>	• <sup>6</sup>	• <sup>3</sup>
		360	72-1/2	725N1081			• <sup>4</sup>			• <sup>4</sup>
		12	48	72	15-1/4	726N0281	• <sup>3</sup>	• <sup>3</sup>	• <sup>2</sup>	• <sup>2</sup>
96	18-1/2			726N0381	• <sup>4</sup>	• <sup>4</sup>	• <sup>2</sup>	• <sup>4</sup>	• <sup>2</sup>	•
120	22			726N0481	• <sup>6</sup>	• <sup>6</sup>	• <sup>3</sup>	• <sup>4</sup>	• <sup>4</sup>	• <sup>2</sup>
144	25-1/4			726N0581	• <sup>6</sup>	• <sup>6</sup>	• <sup>3</sup>	• <sup>4</sup>	• <sup>4</sup>	• <sup>2</sup>
192	32			726N0681	• <sup>8</sup>	• <sup>8</sup>	• <sup>4</sup>	• <sup>8</sup>	• <sup>4</sup>	• <sup>2</sup>
240	38-1/4			726N0781	• <sup>12</sup>	• <sup>12</sup>	• <sup>6</sup>	• <sup>8</sup>	• <sup>8</sup>	• <sup>4</sup>
288	45-1/2			726N0881	• <sup>12</sup>	• <sup>12</sup>	• <sup>6</sup>	• <sup>8</sup>	• <sup>8</sup>	• <sup>4</sup>
384	59			726N0981			• <sup>8</sup>	• <sup>16</sup>	• <sup>8</sup>	• <sup>4</sup>
480	72-1/4			726N1081			• <sup>12</sup>			• <sup>8</sup>

# Flange Heaters

## Oil Heaters

Steel Sheath, Steel Flange

20 W/Sq. In.

Flange Size (Inches)	Number of Elements	KW	NEMA 1 Terminal Box							
			B Dimensions (Inches)	Catalog Number	Availability					
					1 Phase			3 Phase		
					208V	240V	480V	208V	240V	480V
3	3	1.5	10-1/4	721N0141	•	•	•	•	•	•
		3	19	721N0341	•	•	•	•	•	•
		4.5	27-1/2	721N0541	•	•	•	•	•	•
		6	35-3/4	721N0641	•	•	•	•	•	•
		7.5	44-1/4	721N0741	•	•	•	•	•	•
		9	52-1/4	721N0841	•	•	•	•	•	•
5	6	12	69-1/2	721N0941	•	•	•	•	•	•
		4.5	15	722N0241	•	•	•	•	•	•
		6	19-1/4	722N0341	•	•	•	•	•	•
		7.5	23-1/2	722N0441	•	•	•	•	•	•
		9	27-1/4	722N0541	•	•	•	•	•	•
		12	36	722N0641	•	•	•	•	•	•
5	9	15	44-1/2	722N0741	•	•	•	•	•	•
		18	52-1/4	722N0841	•	•	•	•	•	•
		24	69-1/2	722N0941	•	•	•	•	•	•
		9	19-1/4	722N1241	•	•	•	•	•	•
		13.5	27-1/4	722N1441	•	•	•	•	•	•
		18	36	722N1541	•	•	•	•	•	•
5	12	22.5	44-1/2	722N1641	•	•	•	•	•	•
		27	52-3/4	722N1741	• <sup>3</sup>	•	•	•	•	•
		36	69-1/2	722N1841	• <sup>3</sup>	• <sup>3</sup>	•	•	•	•
		12	19-1/4	723N0341	•	•	•	•	•	•
6	12	15	23-1/4	723N0441	•	•	•	•	•	•
		18	27-1/2	723N0541	•	•	•	•	•	•
		24	36	723N0641	•	•	•	•	•	•
		30	44-1/4	723N0741	• <sup>2</sup>	• <sup>2</sup>	•	•	•	•
		36	52-5/8	723N0841	• <sup>2</sup>	• <sup>2</sup>	•	•	•	•
		48	69-1/2	723N0941	• <sup>2</sup>	• <sup>2</sup>	•	• <sup>2</sup>	•	•

Flange Size (Inches)	Number of Elements	KW	NEMA 1 Terminal Box							
			B Dimensions (Inches)	Catalog Number	Availability					
					1 Phase			3 Phase		
					208V	240V	480V	208V	240V	480V
6	15	15	19-1/4	723N1241	•	•	•	•	•	•
		30	36	723N1541	• <sup>3</sup>	• <sup>3</sup>	•	•	•	•
		37.5	44-1/4	723N1641	• <sup>3</sup>	• <sup>3</sup>	•	•	•	•
		45	52-3/4	723N1741	• <sup>3</sup>	• <sup>3</sup>	•	• <sup>5</sup>	•	•
		60	69-1/2	723N1841	• <sup>3</sup>	• <sup>3</sup>	• <sup>3</sup>	• <sup>5</sup>	• <sup>5</sup>	•
8	18	18	19	724N0341	•	•	•	•	•	•
		22.5	23-1/4	724N0441	•	•	•	•	•	•
		27	27-1/2	724N0541	• <sup>2</sup>	•	•	•	•	•
		36	35-3/4	724N0641	• <sup>2</sup>	• <sup>2</sup>	•	•	•	•
		45	44-1/4	724N0741	• <sup>2</sup>	• <sup>2</sup>	•	• <sup>2</sup>	•	•
8	27	54	52-3/4	724N0841	• <sup>3</sup>	• <sup>2</sup>	•	• <sup>2</sup>	• <sup>2</sup>	•
		72	69-1/2	724N0941	• <sup>3</sup>	• <sup>3</sup>	• <sup>2</sup>	• <sup>2</sup>	• <sup>2</sup>	•
		27	19	724N1241	• <sup>3</sup>	•	•	•	•	•
		40.5	27-1/2	724N1141	• <sup>3</sup>	• <sup>3</sup>	•	•	•	•
		54	35-1/2	724N1541	• <sup>3</sup>	• <sup>3</sup>	• <sup>3</sup>	• <sup>3</sup>	•	•
10	36	67.5	44-1/4	724N1641	• <sup>3</sup>	• <sup>3</sup>	• <sup>3</sup>	• <sup>3</sup>	•	•
		81	52-3/4	724N1741	• <sup>9</sup>	• <sup>3</sup>	• <sup>3</sup>	• <sup>3</sup>	•	•
		108	69-1/2	724N1841	• <sup>9</sup>	• <sup>9</sup>	• <sup>3</sup>	• <sup>3</sup>	•	•
		36	19	725N0341	• <sup>2</sup>	• <sup>2</sup>	•	•	•	•
		45	23-1/4	725N0441	• <sup>2</sup>	• <sup>2</sup>	•	• <sup>2</sup>	•	•
10	48	54	27-1/2	725N0541	• <sup>3</sup>	• <sup>2</sup>	•	• <sup>2</sup>	•	•
		72	35-3/4	725N0641	• <sup>3</sup>	• <sup>2</sup>	•	• <sup>2</sup>	•	•
		90	44-1/4	725N0741	• <sup>4</sup>	• <sup>4</sup>	• <sup>2</sup>	• <sup>3</sup>	• <sup>2</sup>	•
		108	52-3/4	725N0841	• <sup>6</sup>	• <sup>4</sup>	• <sup>2</sup>	• <sup>3</sup>	• <sup>3</sup>	• <sup>2</sup>
		144	69-1/2	725N0941	• <sup>6</sup>	• <sup>6</sup>	• <sup>3</sup>	• <sup>4</sup>	• <sup>3</sup>	• <sup>2</sup>
12	48	48	19	726N0341	• <sup>2</sup>	• <sup>2</sup>	•	• <sup>2</sup>	•	•
		60	23	726N0441	• <sup>3</sup>	• <sup>3</sup>	• <sup>2</sup>	• <sup>2</sup>	•	•
		72	27-1/4	726N0541	• <sup>3</sup>	• <sup>3</sup>	• <sup>2</sup>	• <sup>2</sup>	•	•
		96	35-3/4	726N0641	• <sup>4</sup>	• <sup>4</sup>	• <sup>2</sup>	• <sup>4</sup>	• <sup>2</sup>	•
		120	44	726N0741	• <sup>6</sup>	• <sup>6</sup>	• <sup>3</sup>	• <sup>4</sup>	• <sup>4</sup>	• <sup>2</sup>
		144	52-1/2	726N0841	• <sup>6</sup>	• <sup>6</sup>	• <sup>3</sup>	• <sup>4</sup>	• <sup>4</sup>	• <sup>2</sup>
192	69-1/4	726N0941	• <sup>8</sup>	• <sup>8</sup>	• <sup>4</sup>	• <sup>8</sup>	• <sup>4</sup>	• <sup>2</sup>		

Steel Sheath, Steel Flange

Flange Size (Inches)	Number of Elements	KW	NEMA 1 Terminal Box							
			B Dimensions (Inches)	Catalog Number	Availability					
					1 Phase			3 Phase		
					208V	240V	480V	208V	240V	480V
3	3	3	30-1/4	721N4141	•	•	•	•	•	•
		4.5	44-1/4	721N4241	•	•	•	•	•	•
		6	58-1/4	721N4341	•	•	•	•	•	•
		7.5	72-1/4	721N4441	•	•	•	•	•	•
		9	86	721N4541	•	•	•	•	•	•
5	6	4.5	23-1/2	722N5141	•	•	•	•	•	•
		6	30-1/2	722N5241	•	•	•	•	•	•
		9	44-1/2	722N5341	•	•	•	•	•	•
		12	58-1/4	722N5441	•	•	•	•	•	•
		15	72-1/4	722N5541	•	•	•	•	•	•
6	12	18	86-1/4	722N5641	•	•	•	•	•	•
		9	23-1/2	723N6141	•	•	•	•	•	•
		12	30-1/4	723N6241	•	•	•	•	•	•
		18	44-1/4	723N6341	•	•	•	•	•	•
		24	58-1/2	723N6441	•	•	•	•	•	•
6	12	30	72-1/4	723N6541	• <sup>2</sup>	• <sup>2</sup>	•	•	•	•
		36	86-1/4	723N6641	• <sup>2</sup>	• <sup>2</sup>	•	•	•	•

•<sup>2</sup>= Superscript indicates number of circuits.

Please specify volts, phase, circuits, terminal box rating and, if needed, thermostat range from options listed on page 27.

ANSI Flanges are available in larger sizes through 26".

12 W/Sq. In.

Flange Size (Inches)	Number of Elements	KW	NEMA 1 Terminal Box							
			B Dimensions (Inches)	Catalog Number	Availability					
					1 Phase			3 Phase		
					208V	240V	480V	208V	240V	480V
8	18	13.5	23-1/4	724N7141	•	•	•	•	•	•
		18	30-1/4	724N7241	•	•	•	•	•	•
		27	44-1/4	724N7341	• <sup>2</sup>	•	•	•	•	•
		36	58-1/4	724N7441	• <sup>2</sup>	• <sup>2</sup>	•	•	•	•
		45	72-1/4	724N7541	• <sup>2</sup>	• <sup>2</sup>	•	• <sup>2</sup>	•	•
10	36	54	86	724N7641	• <sup>3</sup>	• <sup>2</sup>	•	• <sup>2</sup>	• <sup>2</sup>	•
		27	23-1/4	725N8141	• <sup>2</sup>	•	•	•	•	•
		36	30-1/4	725N8241	• <sup>2</sup>	• <sup>2</sup>	•	•	•	•
		54	44-1/4	725N8341	• <sup>3</sup>	• <sup>2</sup>	•	• <sup>2</sup>	• <sup>2</sup>	•
		72	58-1/4	725N8441	• <sup>3</sup>	• <sup>3</sup>	• <sup>2</sup>	• <sup>2</sup>	• <sup>2</sup>	•
12	48	90	72-1/2	725N8541	• <sup>4</sup>	• <sup>4</sup>	• <sup>2</sup>	• <sup>3</sup>	• <sup>2</sup>	•
		108	86	725N8641	• <sup>6</sup>	• <sup>4</sup>	• <sup>2</sup>	• <sup>3</sup>	• <sup>3</sup>	• <sup>2</sup>
		36	23-1/4	726N9141	• <sup>2</sup>	• <sup>2</sup>	•	•	•	•
		48	30	726N9241	• <sup>2</sup>	• <sup>2</sup>	•	• <sup>2</sup>	•	•
		72	44	726N9341	• <sup>3</sup>	• <sup>3</sup>	• <sup>2</sup>	• <sup>2</sup>	• <sup>2</sup>	•
12	48	96	58	726N9441	• <sup>4</sup>	• <sup>4</sup>	• <sup>2</sup>	• <sup>4</sup>	• <sup>2</sup>	•
		120	72	726N9541	• <sup>6</sup>	• <sup>6</sup>	• <sup>3</sup>	• <sup>4</sup>	• <sup>4</sup>	• <sup>2</sup>
		144	86	726N9641	• <sup>6</sup>	• <sup>6</sup>	• <sup>3</sup>	• <sup>4</sup>	• <sup>4</sup>	• <sup>2</sup>



## Heater Options

**Built-In Thermostat** - For fluid temperature control or high limit control. Available in NEMA 1 or liquidproof boxes. See page 21 for outlet box dimensions. Thermostat suitable for pilot duty operation only.

Specify temperature range:

0-100° F, 40-120° F, 60-250° F or 150-550° F

Pilot duty rating:

125 VA up to 240 Volts

**Integral Thermostat Well** - To protect and locate the bulb of a remotely mounted thermostat. Specify well length below flange and inside diameter if the thermostat is supplied by others.

**Thermocouple Attached to Sheath** - To monitor or limit the sheath temperature. Thermocouple is field-connected to control or to indicating device through jacks furnished in the outlet box. Type K Chromel-Alumel thermocouples with 316 stainless steel sheath, suitable for 1500° F maximum, are standard. Thermocouple is attached to an element in the first circuit near the U-bend unless an alternate location is specified.

**Liquidproof/Explosion-Resistant Outlet Boxes** - Steel boxes with threaded or bolted cover and female threaded hubs for electrical connections. For applications where there is danger of moisture entering the outlet box or for hazardous locations classified by the National Electrical Code. Consult factory for other types of hazard.

**Hermetic Seals** - For applications where an absolute moisture seal is required. Each element is fitted with ceramic-to-metal hermetic seals, which are airtight and impervious to outside influences. Seals are designed for terminal temperatures up to 1000° F.

**Epoxy Seals** - For moisture resistance where the fluid temperature does not exceed 250° F. Each element is sealed with epoxy as a barrier against moisture entering the element. Furnished as standard on copper-sheathed heaters.

**RTV Seals** - For moisture resistance where the fluid temperature does not exceed 400° F.

**ASME partial stamp** - Please provide design temperature, pressure and corrosion allowance.

**Low flow spacers** - For applications inside vessels where the pressure drop is critical.

**Class 150 Stainless Steel Flanges** - Type 304 stainless steel flanges are available where steel flanges may corrode and for fluid temperatures above 800° F. Stainless steel, Incoloy or Inconel elements are welded to the flange; copper elements are silver soldered. See page 19 for pressure/temperature ratings. Consult factory for higher pressure ratings.

**Class 300 Steel Flanges** - For use where pressure and/or temperature exceed the ratings of standard Class 150 flanges. See Table III for pressure/temperature ratings. Consult factory for steel flanges rated over Class 300, flanges rated Class 600, 900 and 1200 are available with extended lead times.

**Larger Flanges** - For added KW capacity, or to reduce pressure drop through the heater, larger flanges are available. Standard ANSI flanges available up through 26".

**Special Flange Materials** - Type 316 stainless steel, Incoloy 800, Inconel 600 and Monel 400 flanges are available with elements of matching sheath material for applications where all wetted surfaces are subject to the same corrosion requirements.

**Spirallic Gaskets** - Spiral wound Type 304 stainless steel gaskets recommended for extremes in joint relaxation, temperature or pressure cycling, shock or vibration.

**Insulated Flange** - Ceramic wool insulation 3" thick is used to reduce heat transfer from the fluid into the terminal box. Recommended for fluid temperatures over 500° F where the fluid temperature exceeds the field wiring insulation rating by more than 50° F, and for dual-purpose heating/cooling applications to prevent condensation in the terminal box during the cooling cycle.

**Longer Element Cold Ends** - Standard cold ends, 2" for copper, stainless and steel; 5" for Incoloy. In vertically mounted heaters and other applications where the liquid will not completely cover the elements, immersion length should be increased by the length of additional cold end.

**Longer Elements** - Immersion lengths up to 192" available for applications requiring lower watt densities or heat distribution throughout a long vessel.

**Special Bending Configurations** - For unusual tank designs or to keep elements covered at all times. For example, elements are normally curved or bent for lube oil reservoirs on shipboard to assure coverage as the ship rolls.

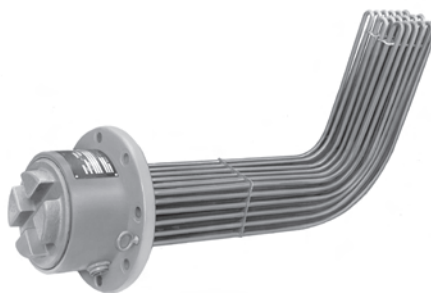

# Flange Heaters

## Heater Options (continued)

**Special Sheath Material** - For compatibility with fluid composition and fluid temperature. See Table I for material recommendations. Monel 400, Inconel 600 and Type 316 stainless steel are available.

**Iron Content** - In critical processes where no trace of iron can be tolerated, stainless steel heaters can be electropolished before installation.

**Additional Circuits** - For staged control of heater load. Standard number of heater stages shown in listing tables. Additional stages available consistent with number of elements. (Multiple of three elements required for three-phase circuits.)

**Special Ratings** - Non-standard KW ratings and special watt densities, required for certain fluids, are available.

**Agency Approval** - Most pipe flange heaters listed have been approved by CSA (Canadian Standards Association) under File No. LR11895-35. Ratings available up to 600 volts.

Explosion-proof pipe flange heaters have been approved by FM (Factory Mutual), CSA and L.C.I.E. (French Approval Agency) for use in Class I; Divisions 1, 2; Groups B, C, D hazardous locations. These explosion-proof immersion heater approvals include testing to the requirements of European CENELEC Standards EN50014 and EN50018. Consult factory for more information.

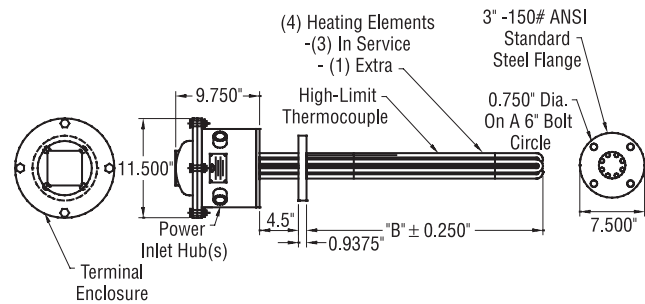

**Compliance with Military Specifications** - Heaters are available to meet a variety of military specifications. For example, for heating lubricating oil on shipboard, we furnish heaters per MIL-H-24299 with hermetic seals and liquidproof outlet boxes, tested per the specification. For water purification, we have furnished heaters per MIL-H-22577C. For heating hydraulic fluid, we have furnished heaters per MIL-S-901 and MIL-STD-167 covering special shock and vibration requirements.

**High Temperature Construction** - When the outlet box temperature exceeds 250° F, mica terminal insulators are furnished, and properly sized lugs and conduit openings for incoming wiring are provided. Above 500° F an extended terminal box is standard.