

Control Panels

INDEECO can provide a control system for any electric process heating application. Standard and custom sized enclosures, along with custom designed control operation, give INDEECO the flexibility to supply a wide range of remote, built-on or skid-mounted control panels to complete the heater control system. Our experienced engineering staff can design control systems ranging from ON/OFF logic

to fully proportional SCR, multiple channel and ramp/soak control with computer interface capability.

INDEECO offers two standard control panel designs: Fully proportional SCR control and ON/OFF contactor control. All components are factory mounted and wired in compliance with the National Electric Code.

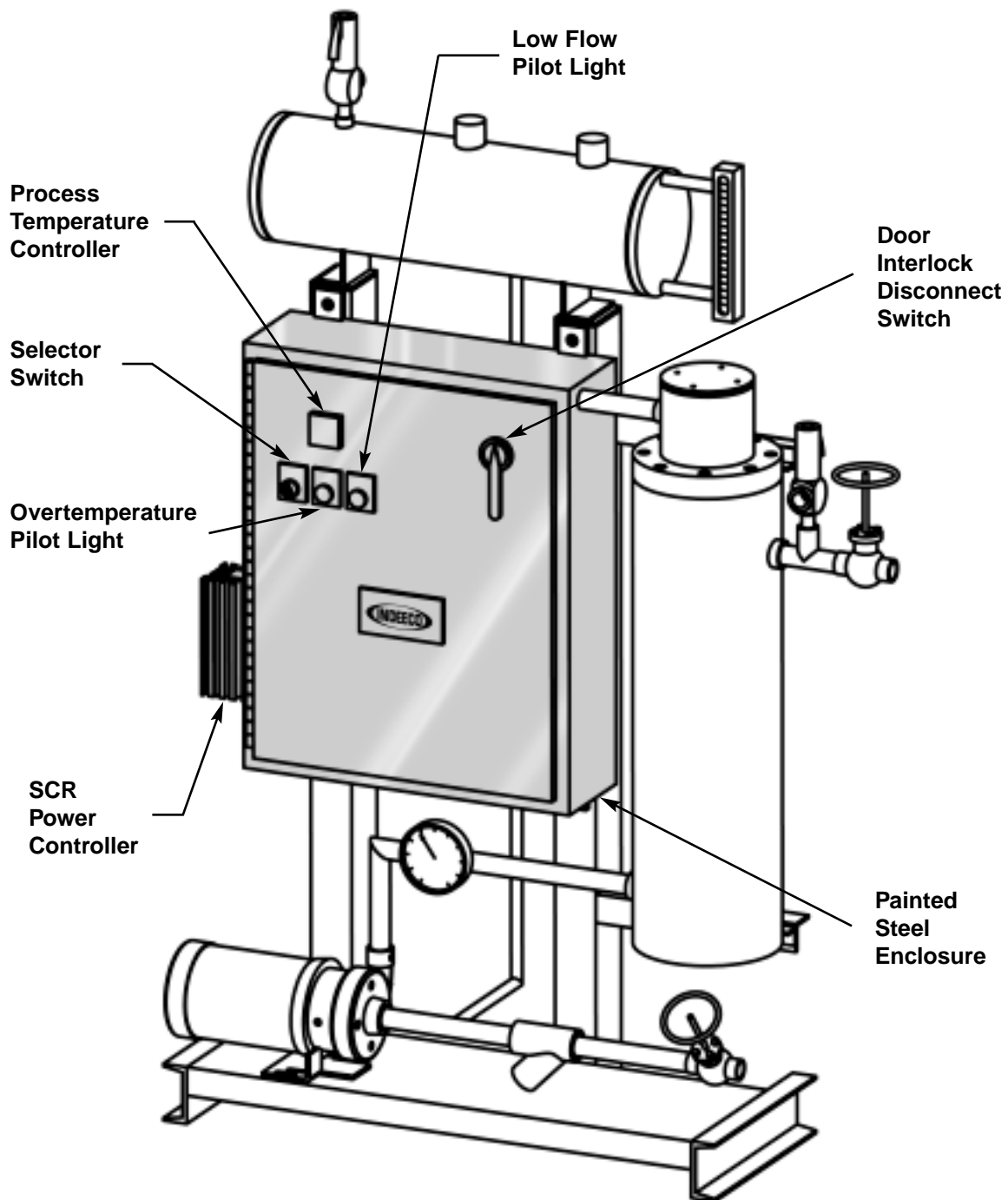

These charts provide a sample of standard control panel designs. Custom control panels, designed specifically for your application, are available.

A Vernier control panel can also be supplied. Vernier control utilizes contactors, one SCR controller, and a microprocessor-based sequencer. The sequencer controls the staging of the contactors and the SCR controller. The SCR controller serves to fill in the gaps between the step-controlled stages. Vernier control is not quite as accurate as full SCR control, but more accurate than contactor (step) control.

Contactor Control Panels

This contactor-based system with ON/OFF process temperature control is recommended for less demanding applications. Systems with two or more heating stages utilize an INDEECO Controls electronic sequencer (step controller), driven by a proportional output temperature controller to minimize the amount of load cycling while providing good outlet temperature control.

Standard Features:

- INDEECO microprocessor-based sequencer (for panels with two or more heating stages)
- Proportional indicating temperature controller (adjustable process temperature with thermocouple input)
- NEMA 12 painted steel enclosure, wall mount unless otherwise noted
- Overtemperature controller (adjustable temperature limit with thermocouple input)
- Door interlock disconnect switch
- Manual reset pushbutton with built-in pilot light (red) for visual "OVERTEMPERATURE" alarm
- Selector switch – ON/OFF with built-in pilot light (green) for "POWER ON" indication
- Control transformer
- Disconnecting magnetic contactors
- Circuit fusing

Amps	Number Of Circuits	Amps Per Circuit	Maximum KW		Approximate Dimensions (Inches)			Estimated Weight (Lbs.)
			240V/3PH	480V/3PH	Height	Width	Depth	
48	1	48	19	39	24	24	8	85
96	2	48	39	79	30	24	8	105
144	3	48	59	119	36	30	8	160
192	4	48	79	159	42	30	8	175
240	5	48	99	199	48	36	8	260
288	6	48	119	239	48	36	8	265
336	7	48	139	279	60	36	8	320
384	8	48	159	319	60	36	8	330
432*	9	48	179	359	60	48	12	585
480*	10	48	199	399	60	48	12	600
528*	11	48	219	438	60	60	12	680
576*	12	48	239	478	60	60	12	685
624*	13	48	259	518	72	60	12	800
672*	14	48	279	558	72	60	12	805
720*	15	48	299	598	72	60	12	815
768*	16	48	319	638	72	72	12	930
816*	17	48	339	678	72	72	12	945
864*	18	48	359	718	72	72	12	950
912*	19	48	379	758	72	72	12	960
960*	20	48	399	798	72	72	12	965

*These panels have double doors and 12" high floor stands.

Control Panels

SCR Control Panels

A fully proportional SCR system with PID temperature control is recommended for industrial heating applications which must accommodate material flow changes and provide the highest degree of accuracy for outlet temperature control.

Standard Features:

- PID self-tuning temperature controller (adjustable process temperature, with thermocouple input)
- INDEECO three-phase, zero cross-fired, SCR power controllers
- NEMA 12 painted steel enclosure, wall mount unless otherwise noted

- Overtemperature controller (adjustable temperature limit with thermocouple input)
- Door interlock disconnect switch
- Manual reset pushbutton with built-in pilot light (red) for visual "OVERTEMPERATURE" alarm
- Selector switch – ON/OFF with built-in pilot light (green) for "POWER ON" indication
- Control transformer
- Safety contactors
- Circuit fusing
- Ventilating fan and filter when required

Amps	Number Of Circuits	Amps Per Circuit	Maximum KW		Approximate Dimensions (Inches)			Estimated Weight (Lbs.)
			240V/3PH	480V/3PH	Height	Width	Depth	
SCR panels with externally mounted heat sinks								
48	1	48	19	39	24	24**	8	95
70	1	70	29	58	30	24**	8	115
96	2	48	39	79	30	24**	8	125
140	2	70	58	116	42	30**	8	205
144	3	48	59	119	36	30**	8	195
210	3	70	87	174	48	36**	8	310
192	4	48	79	159	42	30**	8	225
280	4	70	116	232	60	36**	8	385
240	5	48	99	199	48	36**	8	320
350	5	70	145	290	60	36**	8	415
SCR panels with internally mounted heat sinks, fan and filter								
295	6	48	119	239	60	36	16	405
425*	9	47	175	351	60	48	16	660
590*	12	48	239	478	60	60	16	750
850*	18	47	351	703	72	72	16	1090

*These panels have double doors and 12" high floor stands.

**Additional 9" clearance required for externally mounted heat sinks which may be mounted on one or both sides of the enclosure for proper convection cooling.

SCR Power Controllers modulate the entire heater load directly, varying the heater output from 0 to 100% of the total heater KW. Working on a four second time base, the heater will be energized only for the number of AC cycles necessary to produce the exact amount of heat required. The resulting precision control and rapid response make the INDEECO Controls SCR the choice for many heating applications. For example, multi-stage discharge temperature control of a heater can produce unacceptable temperature

swings, resulting in inefficient energy use. The same heater controlled by the SCR and process temperature controller will produce stable, even heat for maximum performance and efficiency.

The SCR's power switching devices are mounted on a large finned heat sink which extends outside the heater terminal box or control panel. The conservative SCR rating (no more than 75% of the manufacturer's rating) and this generous heat sink insure against overheating and SCR failure.

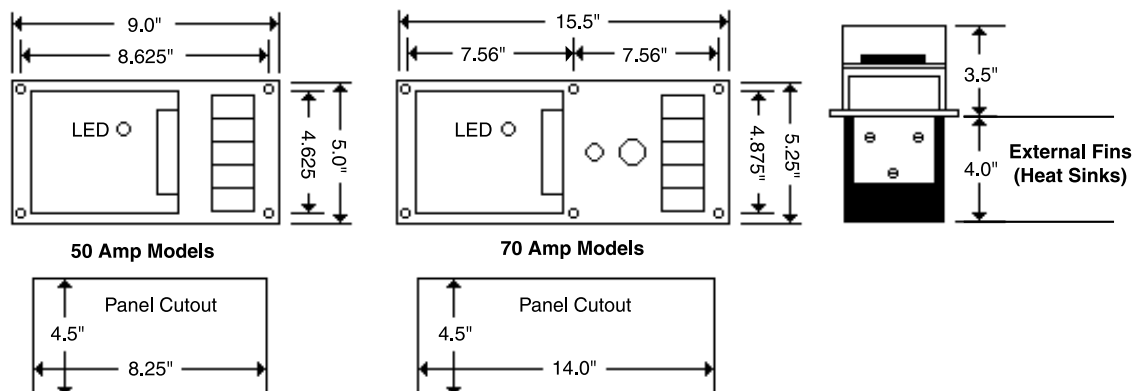

Special Features

Control Relays – These relays are activated by safety devices, such as a flow switch or remote shutoff.

Remote Interlock Terminals – Control circuit terminals are supplied so the heater can be de-energized from remote contacts.

Indicator Lights – Additional indicator lights may be specified for visual indication of system status, such as "LOW TEMPERATURE".

Audible Alarm Package – This package includes a horn, pilot light, latching relay and a push button for silencing the horn.

Low Liquid Cutoff – The relay is mounted and wired with sensing probe shipped loose for field installation.

Skid Mounted Panel – The control panel and heater are mounted together and prewired on a rugged steel skid. This provides a modular system that minimizes installation time and expense.

Special Controllers – The customer may specify the use of special process or overtemperature controllers for a different temperature range, sensor input, control mode, etc.

Panel Heater – A heater and thermostat are provided to prevent condensation and maintain minimum ambient temperature for electrical components.

Wire Markers – Identification markers are attached to both ends of all control and power wires.

Tagging of Internal Parts – Permanent tags are attached to the subpanel near internal parts and marked with component titles as noted on the wiring diagram.

UL Listing – Available on most designs.

Explosion-Resistant Panel – A cast aluminum enclosure is rated for Class I, Groups C & D and Class II, Groups E, F & G (NEMA 7, 9).

Purged Panels – Type Z for Class I, Division 2 areas
Type X for Class I, Division 1 areas



Special Coatings – Epoxy or other paints may be specified.

12" High Floor Stand – This construction allows the control panel to be floor mounted.

NEMA 4 Panel Enclosure – Features a gasketed weatherproof construction.

NEMA 4 Instrument Window – This feature allows for access to a control instrument without opening the control panel door.

Stainless Steel Panel Enclosure (NEMA 4X) – This construction provides extra corrosion resistance for harsh environments.