

Typical Applications

INDEECO circulation heaters are used to maintain, raise, preheat and boost process temperatures from -50° F to 1200° F for a wide variety of liquids and gases found in commercial, industrial and military applications.

- Adhesives
- Air Heating (Process)
- Ammonia
- Anodizing Equipment
- Automotive and Engines
- Chemical Processing
- Curing
- Cryogenic Processing
- Degreasing Tanks
- Desalination Equipment
- Dessicant Drying
- Drying
- Food Processing
- Freeze Protection
- Fuel Oils
- Gasoline Refining
- Heat Transfer Systems
- High Pressure Air or Gases
- Hydraulic Oils
- Laboratory Work
- Lubrication Oils
- Metal Cleaning Baths
- Nitrogen
- Oil Purifiers
- Oil Refining
- Oils
- Paint Lines
- Pasteurizing
- Pipeline Heating
- Plastic Machinery and Processes
- Platens
- Plating Tanks
- Preheating
- Presses
- Process Air and Liquids
- Purification Systems
- Rinsing/Cleaning
- Rolls and Cylinders
- Steam Heating
- Superheating
- Tank Heating (Process, Storage)
- Textiles
- Wash Tanks
- Waste Water/Sewage Treatment
- Water (Deionized, Potable, Process)

System Configurations

Closed Loop Systems

The circulation heater is installed in a system where the liquid or gas to be heated is recirculated through the heater in a closed loop configuration.

Applications of this method fall into the two distinct categories of Indirect and Direct Heating.

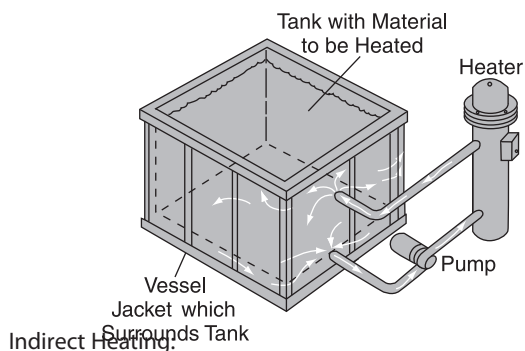

A heating medium such as Dowtherm, Therminol, ethylene glycol, water, oil or steam is heated as it flows through the heater. The heating medium is continuously recirculated through coiled tubing, pipes or vessel jackets which are wrapped around or inserted directly into storage tanks, vessels, molds, dies, presses and rolls which are to be heated.

Typical Applications Include:

Viscous fluids and other temperature sensitive materials such as adhesives, asphalt, chocolate, syrups and varnish found in tanks and process vessels.

Corrosive materials like acids and chemicals which would quickly corrode heating elements directly immersed in the material.

Platens, molds, presses or rolls found in plastic injection molding/extrusion processes, textile industries and food processing plants. Some systems may involve high temperatures and pressures.

Circulation Heaters

System Configurations (continued)

Direct Heating:

The process liquid or gas is recirculated directly through the heater in a closed loop system. Selecting the proper element watt density is very important. If the watt density is too high, the process fluid may carbonize or break down chemically.

Typical Applications Include:

Testing systems such as a test stand where the circulation heater is used to maintain uniform oil temperature during the testing of automobile engines. Laboratories and R & D centers have similar applications for a wide variety of liquids and gases.

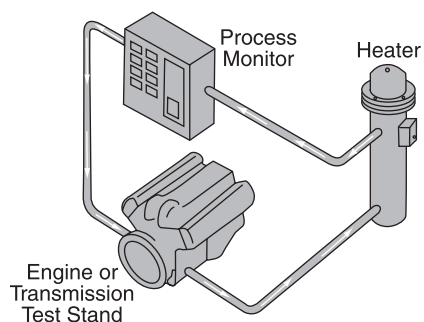

Drying systems where recirculated air or steam is heated or boosted to dry inks, textiles, bottles, pharmaceutical powders, cure parts or remove moisture from pressurized air systems.

Winter freeze protection for water tanks, cooling towers and sprinkler systems.

Diesel generator sets where cooling water and lubrication oil must be kept warm to assure fast start-up in cold weather.

Lubrication and hydraulic oil heating for maintaining the correct oil temperature and viscosity which is crucial for efficient operation of the pumps, transmission, engine or other equipment in the closed loop system.

Industrial processing tanks or baths which use the circulation heater to provide precise temperature control for oil quenching, cleaning tanks, rinsing tanks, degreasing tanks and water baths.

Advantages of circulation heater systems compared to direct immersion heaters for tank heating applications include:

- Heating elements are located away from areas of heavy sludge build-up or possible physical damage.
- Tank interior is kept open for process operations.
- Tank is easier to clean.
- Heater can be removed for inspection without draining the storage tank.

Open Heating Systems

The circulation heater is used in a system where the liquid or gas flows through the heater only once and is discharged directly into the application.

Typical Applications Include:

Booster heating systems which increase the temperature of the liquid, gas or steam just prior to being discharged directly into applications, such as steam cleaning, commercial dishwashers and high temperature process gas heating.

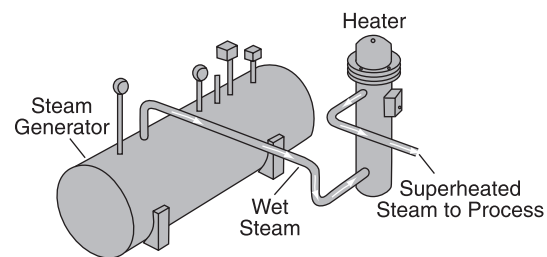

Fuel oil heating where the circulation heater raises the temperature of fuel oil to reduce its viscosity, facilitating its flow into the burner.

Spraying systems which use the heater to reduce viscosity or preheat the material before being pumped into a spray nozzle. For example, heavy petroleum is heated before it is sprayed over the top of coal to reduce dust and coal from being blown out of open railroad cars.