

Circulation Heaters

Mechanical and Electrical Guidelines

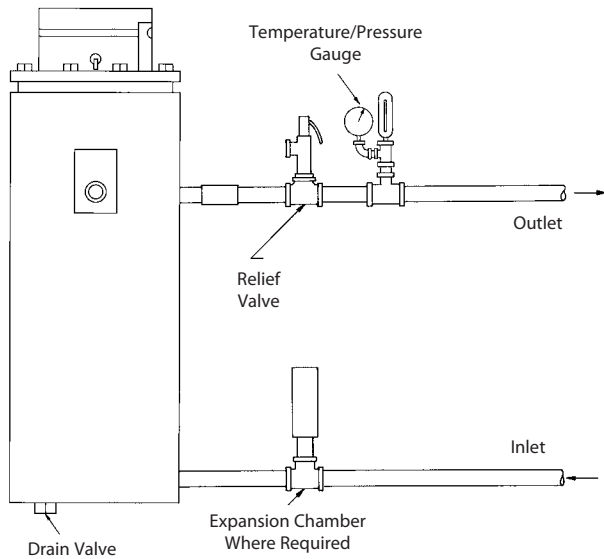

Review the following mechanical and electrical guidelines to specify the best heater design to meet your installation and performance requirements.

Mechanical and Plumbing

INDEECO offers six mounting options. Be sure to specify the appropriate mounting configuration for your application. Consider how you will install the heater and make the plumbing and electrical connections. Leave room for the pull space required to remove the immersion heater from the vessel for inspection, cleaning or replacement.

Verify that the standard circulation heater inlet/outlet location, size and type are appropriate for your installation.

Circulation heaters are designed to heat a fluid or gas as it flows through the vessel. These units are not intended to be used as storage tanks.

When a circulation heater is installed in a pressurized system, a relief valve must be installed in the outlet line. INDEECO can supply a pressure relief valve either built-on or as a loose accessory for field installation.

Do not place a shutoff of any type between the pressure relief valve and the circulation heater or on the discharge pipes between the relief valve and the atmosphere.

A drain plug is furnished in each vessel for periodic sludge removal and maintenance. A gate valve should be specified if frequent draining is required.

When the piping system includes a fast-acting valve or check valve, a customer supplied expansion chamber is recommended.

Adequate provision should be made for expansion and contraction of piping connected to the circulation heater.

The standard circulation heater construction is not designed for wet or hazardous locations. For these applications, a moisture and/or explosion-resistant construction, and a weatherproof insulation jacket are required.

Electrical

The standard circulation heater construction includes a factory-mounted, single stage, Type DA thermostat. This device is available in both two and three-pole models which have the following load carrying capacities:

Table IV

Voltage	Single-Phase (KW)	Three-Phase (KW)
120	3.6	—
208	6.2	10.8
240	7.2	12.4
277	8.3	—
480	9.6	—

Heaters rated above these capacities require a magnetic contactor, with the pilot duty DA thermostat controlling the contactor holding coil. INDEECO offers a convenient built-on contactor option. Figures 10 and 11 show typical wiring diagrams for both a load carrying thermostat and pilot duty thermostat with contactor either supplied by the customer in a remote panel, or built-on to the heater by INDEECO. Note that one contactor is required for each heater stage when optional two-stage thermostat is specified.

A Type DA thermostat must always be mounted in a vertical plane, never "on its back", so be sure to specify the correct heater mounting configuration to assure the thermostat will be correctly oriented and factory-mounted.

INDEECO recommends some type of process overtemperature protection for all circulation heater systems. Options include:

- Built-on Type EC thermostat.
- Built-in thermocouple for remote process overtemperature controller.
- Pump interlock, if a chance exists the heater could be energized with no flow, such as built-in or customer field-installed flow switch or field-installed pump interlock relay.

High limit protection can be provided to prevent element overheating and burnout due to low liquid level, inadequate

Circulation Heaters

Heaters rated above these capacities require a magnetic contactor, with the pilot duty DA thermostat controlling the contactor holding coil. INDEECO offers a convenient built-on contactor option. Figures 10 and 11 show typical wiring diagrams for both a load carrying thermostat and pilot duty thermostat with contactor either supplied by the customer in a remote panel, or built-on to the heater by INDEECO. Note that one contactor is required for each heater stage when optional two-stage thermostat is specified.

A Type DA thermostat must always be mounted in a vertical plane, never "on its back", so be sure to specify the correct heater mounting configuration to assure the thermostat will

$$\text{New KW} = \frac{(\text{New Voltage})^2}{(\text{Rated Voltage})^2} \times \text{Rated KW}$$

Figure 12 shows a circulation heater system wiring diagram with heater, pump and control panel which includes controlling thermostat, high limit protection, controlling contactor, pump motor starter interlock, flow switch with time delay relay, circuit fusing, transformer and power disconnect switch.

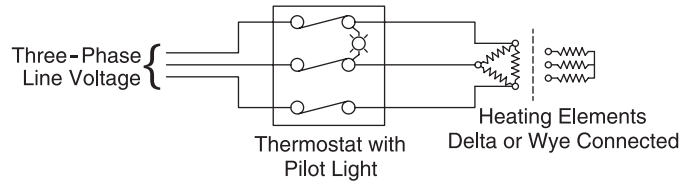

Figure 10

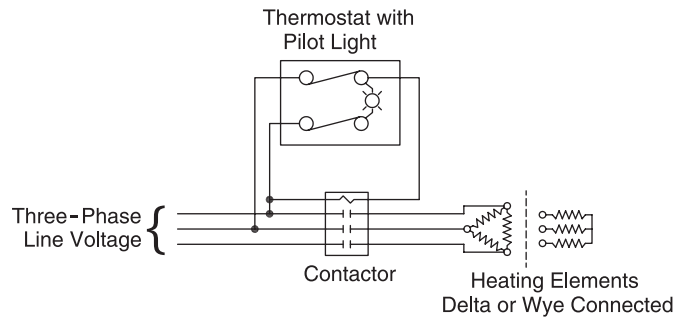

Figure 11

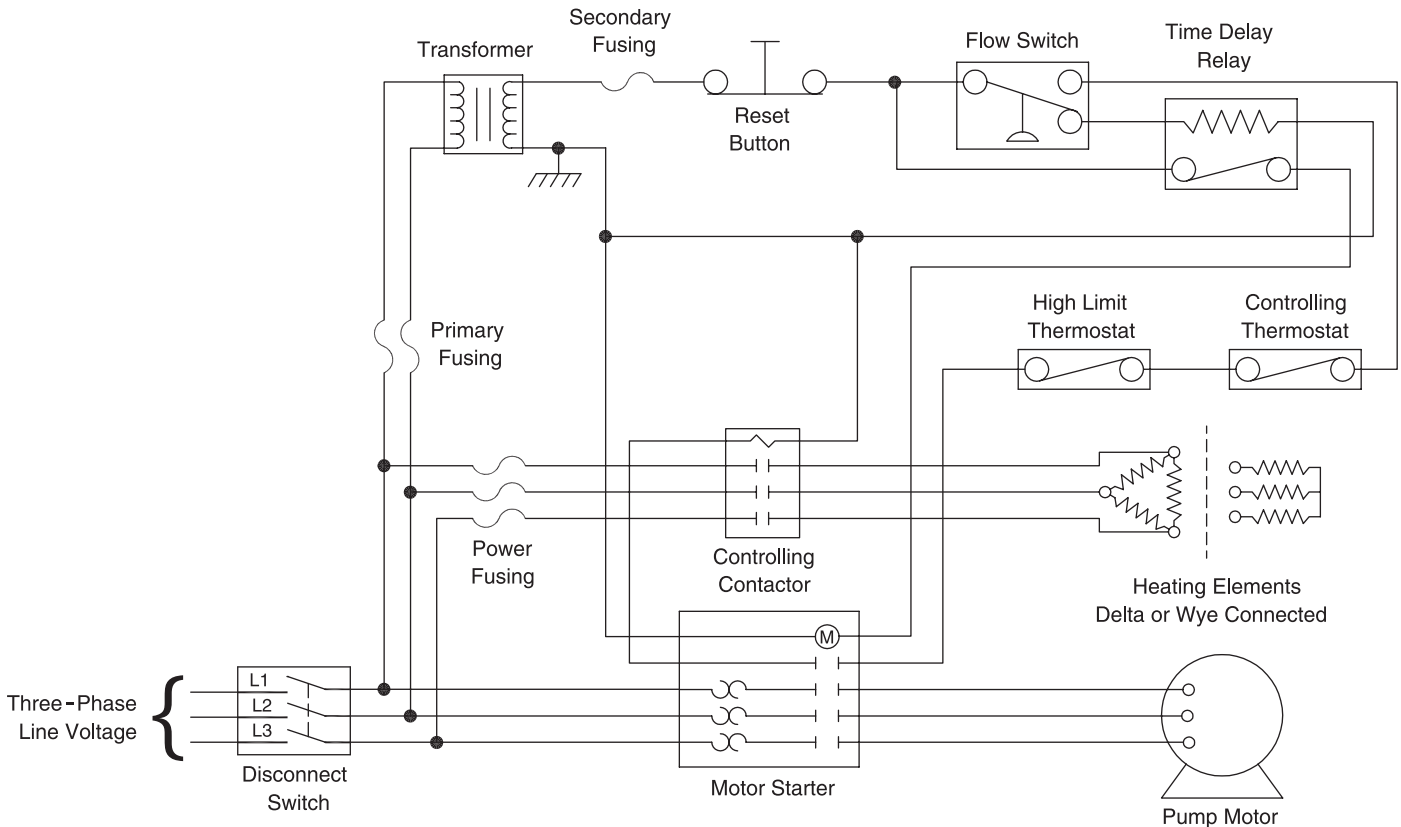

Figure 12