

Commercial Wall Heater

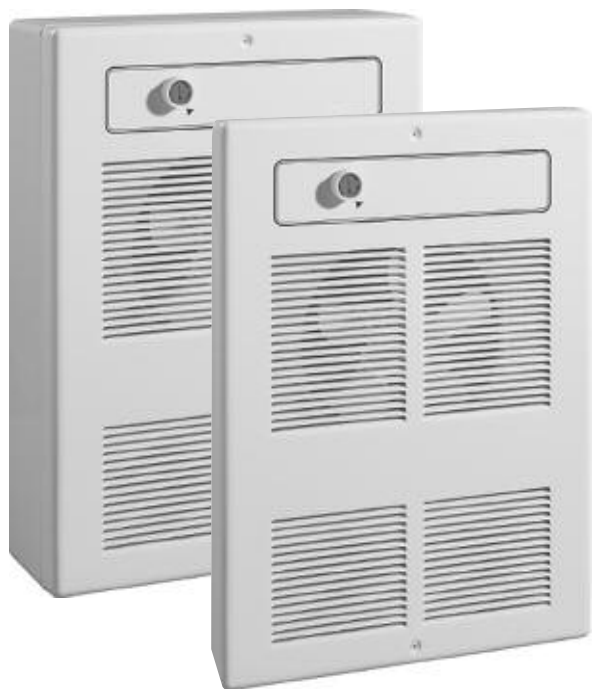

The WCI fan-forced wall heater is designed for commercial and industrial areas requiring higher KW ratings and quick recovery. The unit provides a burst of heat in areas affected by cold drafts or wide temperature swings.

- **Efficient Operation:** The fan draws air into the top of the grille and discharges warm air downward to distribute heat and keep floors warm and dry. High CFM's create air circulation within the room to provide uniform temperatures.
- **Extended Capacity:** The WCI is available with one, two or three modules and ratings up to 12,000 W at 480 CFM.

Applications

- Entryways
- Garages
- Guard Houses
- Offices
- Reception Areas
- Restrooms
- Stairwells
- Vestibules

Standard Construction Features

Heating Elements – Steel finned tubular elements.

Outlet Grille – The WCI has an 18-gauge steel grille with rounded corners and an epoxy-polyester powder paint finish in white or almond. The external thermostat adjustment knob can be replaced with the concealing plug provided for tamperproof construction.

Built-in Controls – Automatic reset thermal cutout, fan override and thermostat (32° to 120°F).

Fan Motor – Permanently lubricated, totally enclosed fan operates at a low 58 dBA.

Installation Requirements – Standard supply wiring rated at 60°C can be used for installation of wall heaters. Heater must be installed at least ten inches from the floor and adjacent walls.

Commercial Wall Heater

Factory Built-in Options

Code	Description
D1	Disconnect Switch, 600V, Three-pole, 40 Amp
D2	Disconnect Switch, 600V, Three-pole, 80 Amp
D3	Disconnect Switch, 277V, Double-pole, 20 Amp
R1	24 Volt Relay
R2	24 Volt Relay with Transformer
S3	Fan On/Auto Switch

Remote Room Thermostat – See page 96

Required Wall Depth Opening

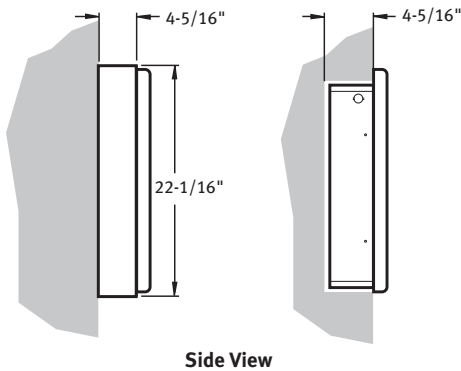

Field-Installed Options

(shipped loose for field installation into heater)

Catalog Number	Description
932-124500	Surface Mounting Box (1500-4800 W)
932-158211	Surface Mounting Box (6000-8000 W)
932-158212	Surface Mounting Box (12000 W)
932-146878	1" Semi Recessed Trim Kit (1500-4800 W)
932-166532	1" Semi Recessed Trim Kit (6000-8000 W)
932-166534	1" Semi Recessed Trim Kit (12000 W)
932-153670	2" Semi Recessed Trim Kit (1500-4800 W)
932-166533	2" Semi Recessed Trim Kit (6000-8000 W)
932-166535	2" Semi Recessed Trim Kit (12000 W)

Standard colors - Add W for white finish or A for almond finish to the end of catalog number.

Special or custom colors - See inside back cover for color codes to be added to end of catalog number.

Grille Dimensions

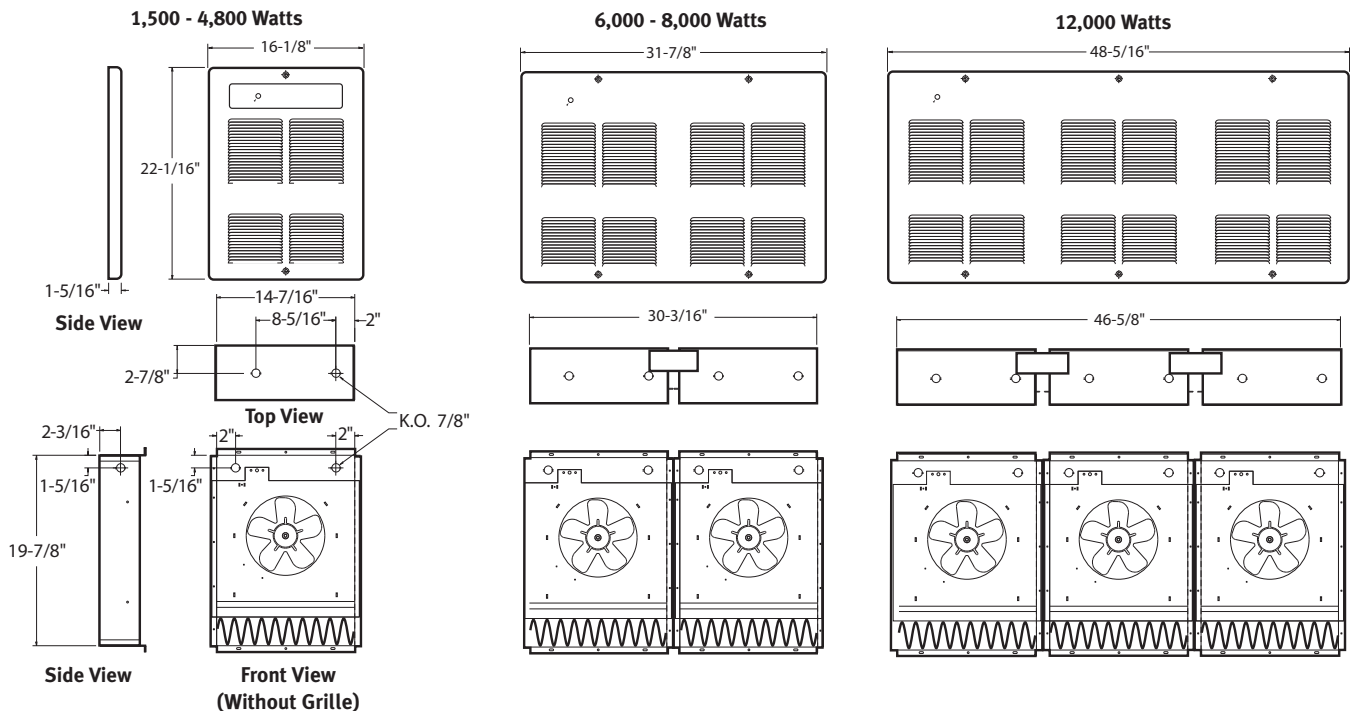

Commercial Wall Heater

Commercial Wall Heater Listing

Adjustable thermostat is included. A hole plug is provided for tamperproof installations.

Watts	Volts	Total Amps (1)	CFM	Approximate Air Temperature Rise °F (°C)	Weight lb (kg)	Catalog Number
1500/1125	240/208	6.6/5.8	160	30/22 (17/12)	24 (11)	932U01500V
1500	277	5.8	160	30 (17)	28 (13)	932U01500N
	480	3.5	160	30 (17)	28 (13)	932U01500T
2000/1500	240/208	8.7/7.6	160	40/30 (22/17)	24 (11)	932U02000V
2000	208	10.0	160	40 (22)	24 (11)	932U02000C
	277	7.6	160	40 (22)	28 (13)	932U02000N
	480	4.6	160	40 (22)	28 (13)	932U02000T
3000/2250	240/208	12.9/11.2	160	60/45 (33/25)	24 (11)	932U03000V
3000	277	11.2	160	60 (33)	28 (13)	932U03000N
	480	6.7	160	60 (33)	28 (13)	932U03000T
4000/3000	240/208	17.0/14.8	160	80/60 (44/33)	24 (11)	932U04000V
4000	208	19.6	160	80 (44)	24 (11)	932U04000C
	277	14.8	160	80 (44)	28 (13)	932U04000N
	480	8.7	160	80 (44)	28 (13)	932U04000T
4800/3600	240/208	20.4/17.7	160	96/72 (53/40)	24 (11)	932U04800V
4800	208	23.5	160	96 (53)	28 (13)	932U04800C
	277	17.7	160	96 (53)	28 (13)	932U04800N
	480	10.4	160	96 (53)	28 (13)	932U04800T
6000/4500	240/208	25.4/22.0	320	60/45 (33/25)	50 (23)	932U06000V
6000	277	22.1	320	60 (33)	50 (23)	932U06000N
	480	12.9	320	60 (33)	50 (23)	932U06000T
8000/6000	240/208	33.7/29.2	320	80/60 (44/33)	50 (23)	932U08000V
8000	208	38.9	320	80 (44)	50 (23)	932U08000C
	277	29.3	320	80 (44)	50 (23)	932U08000N
	480	17.1	320	80 (44)	50 (23)	932U08000T
12000	208/3	33.7	480	80 (44)	90 (41)	932U12000D
	240/3	29.3	480	80 (44)	90 (41)	932U12000K
	277	43.7	480	80 (44)	90 (41)	932U12000N
	480	25.4	480	80 (44)	90 (41)	932U12000T
	480/3	14.8	480	80 (44)	90 (41)	932U12000U

(1) Total Amps = Heating element amps and motor amps.

All models listed are single-phase unless otherwise specified. Other voltages available. Consult factory.

Standard colors - Add W for white finish or A for almond finish to the end of catalog number.

Special or custom colors - See inside back cover for color codes to be added to end of catalog number.