

Construction Mechanical

Slip-In Heaters

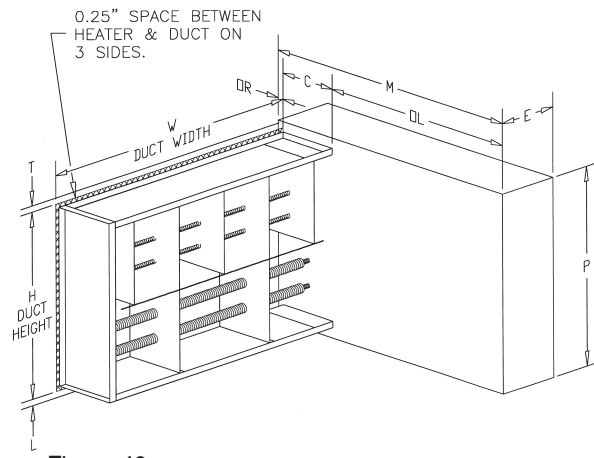

Figure 40.

Slip-in heaters are designed so that the entire frame, except the terminal box, slips into the duct with 1/4" (6.35mm) clearance all around. It is installed, as shown in Figure 8 on page 8, through a rectangular opening in the side of the duct and held in place with sheet metal screws through the back of the terminal box, which is large enough to provide a seal with the duct. Figure 40 illustrates the construction and provides reference dimensions.

Slip-in construction is used because it allows duct work to be installed before the heaters are available, simplifies on-the-job changes in heater location, and is easily retrofitted into existing duct systems. Furthermore, small slip-in heaters may be installed without any special provisions for their support.

While custom slip-in heaters can be provided to fit specific duct dimensions (W x H), selecting standard open coil type QUA heaters maximizes economy and minimizes delivery times.

Flanged Heaters

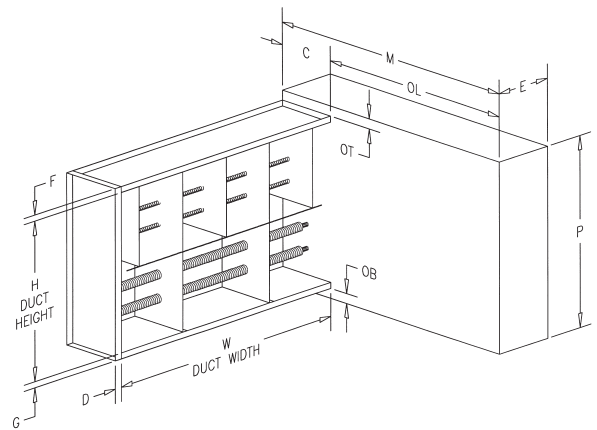

Figure 41.

Flanged construction is available with inside face dimensions exactly matching the duct dimensions. The heater frame is attached to matching turned out duct flanges as illustrated in Figure 9 on page 8. Standard flanges are a minimum of 3/4" deep; deeper flanges are provided on larger heaters for structural reasons. Custom flanges can be provided upon request. Figure 41 illustrates flanged heater construction and provides reference dimensions.

Standard QUZ flanged heaters are available to meet many of the commonly used duct sizes. Listings of the available sizes are shown on page 25. Full range of control options and construction features are offered.

Zero Clearance Construction

Slip-in and flanged heaters are UL Listed for zero clearance, allowing combustible material to be placed directly against exposed surfaces of the heater or surrounding duct work. Although this construction is not required by UL on heaters above 50 KW, INDEECO supplies it on all heaters regardless of KW. However, incorrect mounting will void the UL Listing, and may make the installation unsafe.

Physical Standards

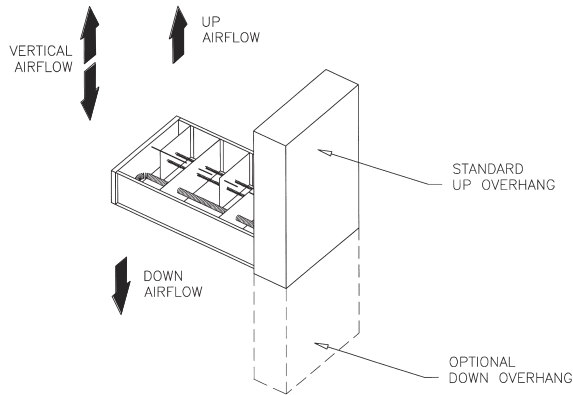

Figure 42.

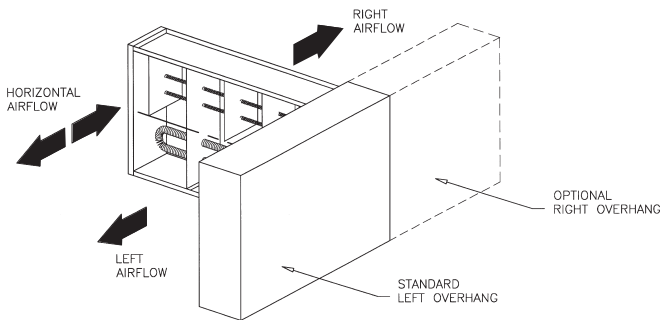

Figure 43.

Standardized dimensions and terminology avoid errors and confusion. The most common dimensions are defined in Figures 40 and 41.

Figures 42 and 43 illustrate airflow terminology. Most INDEECO open coil type heaters are suitable for horizontal or vertical airflow, but for finned tubular type heaters or heaters with pressure plates, exact airflow direction (right, left, up or down) must be specified.

In most heaters, the terminal box is significantly larger than the heater frame, in at least one direction. This is referred to as the terminal box overhang, defined in Figures 42 and 43. For horizontal airflow, left overhang is standard. For vertical airflow, up overhang is standard. Optional right and down overhangs are also available.

Heater Frame and Terminal Box

Frames and terminal boxes are fabricated from heavy gauge corrosion resistant steel. Optional stainless steel frames are recommended for wet or corrosive applications. Standard NEMA 1 type terminal boxes have hinged covers.

Knockouts are provided for all field connections. Open coil heater element support brackets are spaced on 4.5" (114 mm) maximum centers to avoid coil sag, even under the most extreme operating conditions. Strengthening ribs on the brackets insure that coils are held in their proper location, even on large heaters.

Finned tubular heater element support brackets are spaced on 36" (914 mm) maximum centers.

