



INSTALLATION, OPERATING & MAINTENANCE INSTRUCTIONS FOR 881 SERIES IMPEDANCE HEATING SYSTEMS

GENERAL

INDEECO Impedance Heating Systems are designed to provide years of trouble free operation if properly installed and maintained. This system will maintain its design temperature in the piping whether the pipe is full or empty. The piping can be recovered to design temperature if allowed to cool for any reason. The process temperature controller automatically maintains the piping at temperature, and manual manipulation is not required at any time during normal operation or recovery.

CAUTION

Failure to follow INDEECO recommendations could result in premature failure and/or serious equipment damage.

IMPEDANCE HEATING PRINCIPLE

In impedance heating, the wall of the pipe actually becomes the heating element. Alternating current is applied to the pipeline through a step-down transformer that has been specifically designed for the installation. The rapid reversal of current and magnetic flux lines causes self-induction, and this opposition to current flow is called reactance.

heat source is the alternating magnetic flux inducing eddy currents and hysteresis (molecular friction), attributed to the reluctance of the magnetic flux to reverse polarity.

Uniform heating is produced both concentrically around the pipe circumference and along the entire pipe length since the current characteristics are uniform.

Therefore, the impedance to the current flow is caused by the two in combination: Resistance and reactance. A third

EQUIPMENT

Typical System Equipment:

Transformer – The step-down transformer has been specifically designed for the operating conditions. It is a single-phase dry-type unit which will reduce the primary supply voltage (30 volts maximum per NEC standards) to heat the piping. The transformer should be placed within a specified distance from the pipeline, as indicated on the layout drawing.

will result in uneven heating. The limits of pipe length should also be kept, or the system will not operate as designed. The pipe in an Impedance Heating System will carry a low voltage current; therefore, it must be isolated from all electrical grounds. Care must be taken at support points to insure that pipe expansion will not cause accidental grounding of the circuit.

Isolator Kits – Impedance heating produces even heat throughout the circuit. To achieve this, each heating circuit must be electrically uniform from end to end. Since grounding will cause stray currents, and branch circuits at tees will cause currents to divide, isolator kits are used at tees and equipment connections. The isolator kit positions are shown on the outline drawing. These should be located as close as possible to the tees or equipment to prevent any section of piping from being unheated.

Thermal insulation (supplied and installed by customer) – Thermal insulation should be installed to prevent heat loss from the pipe and to protect against accidental contact. The integrity of the thermal insulation must be maintained in order to have the most efficient and maintenance-free system.

Terminal Plates – Terminal plates are designed to carry the current from the cable through the thermal insulation to the pipe.

Thermocouples – Two weld pad mounted thermocouples are used to sense pipe surface temperature. There is one for the process controller and one for the high limit controller. The thermocouples must be of the ungrounded type. The pipe surface temperature will be very close to the fluid temperature in the pipe.

Cable – The secondary cable carries the current to the pipe and should be of adequate cross-section to carry the normal current imposed on the heating system, as shown on the INDEECO drawing.

Typical Control Panel Equipment:

Refer to the wiring diagram included with the control panel.

Pipe (supplied and installed by customer) – The size, schedule and material of the piping for which this system was designed are specified on the outline drawing. All piping should be installed as specified since mixed piping

See individual manufacturer data sheets or IOM's for additional information on components listed below.

Disconnect Switch – Removes line voltage from the control panel for servicing and maintenance.

Fusing – Protects wiring and controls from excessive current due to short circuit or overload.

Power Contactor – Magnetic definite purpose device interlocked with the control circuit to isolate incoming power from the load for ON-OFF control methods or as a safety.

SCR Power Controller – Accepts signal from the Process Temperature Controller and proportions heat output.

Control Transformer – Provides 120VAC power for control circuit.

Process Temperature Controller – Receives a temperature signal from a process sensor or remote input and adjusts system output to maintain required temperature setpoint.

Control Circuit Switch – Pilot device allows the control circuit to be disabled while the main disconnect is on. This allows power to the process controller for configuration and setup.

High Limit Controller – Over-temperature protection that breaks the control circuit when measured process temperature exceeds setpoint. Typically provided with manual reset.

Control Relay – Defines control logic by interlocking safety devices to the system power or can provide remote alarm indication to the customer.

INSTALLATION

CAUTION

INDEECO recommends installation to be performed by qualified personnel familiar with the National Electrical Code and all local codes and standards. It is the responsibility of the installer to verify the safety and suitability of the installation.

WARNING

DO NOT mount Control Panels in an atmosphere containing combustible gases, vapors, dusts, or fibers unless properly marked as suitable for the condition. Refer to section below for special instructions for Hazardous Areas.

WARNING

Hazard of electrical shock. Lock out and tag the branch circuit disconnect switch before working on the Control Panel.

whichever is greater. The depth in front of the panel shall not be less than 3 feet. In all cases, the working space shall permit at least a 90 degree opening of the equipment doors or hinged panels (per NEC Article 110.26).

Mounting

Control panels are provided with either wall or floor mounting. Mount the panel with structural quality bolts matching the size of the holes provided in the mounting feet.

Do not weld to Control Panel to avoid damage to electronic components.

Wiring

The system is furnished with a main disconnect switch and individual circuit fusing. A disconnect switch with fusing can be used in conjunction with either an on-off system (magnetic contactor) or with SCR control. A customer-supplied circuit breaker can be used only in combination with the SCR control; otherwise, use dual element time delay fuses, Class RK5. The reason that a circuit breaker should not be used with an on-off system is the high inrush, which is inherent to any Impedance Heating System, could cause nuisance tripping. The same conditions in combination with an SCR control would not trip the breaker because the “Phase Angle” or “Soft Start” SCR used has a built-in capacity to absorb the inrush, thus preventing the breaker from tripping.

The electrical installation should include a service disconnect switch in sight of the panel, as well as branch circuit over-current protection and over-temperature protection, if not provided with the panel.

The size and type of incoming and interconnecting field wiring will depend upon system current draw and wire insulation rating. The control panel temperature can be assumed to be 130°F max. Field supplied conductors must be sized for at least 125% of the circuit current.

Storage and Handling

Care must be taken to avoid damage to the Control Panel and system components during storage and handling.

Protect the Control Panel from weather damage during storage. It is recommended to store the Control Panel in a cool, dry area when possible. Ensure all openings are tightly sealed if stored outdoors.

Control Panel

Site Selection

Review the NEMA type rating of the Control Panel noted on the nameplate. Do not install a Control Panel in an area inconsistent with its rating.

Allow sufficient free space around panel installation site. Working space for panel maintenance should be at least the width of the panel or 30 inches, whichever is greater. Height must be the height of the panel or 78 inches,

The control panel is completely wired internally. Refer to the wiring diagram for wiring recommendations. An additional copy is provided inside the panel. Review the field wiring requirements carefully. Select instrument wiring to properly match the required signal. Shielded cable is recommended for low voltage and thermocouple signals to minimize 60Hz noise. Shields must be grounded at one end only to prevent a ground loop.

Where thermocouple extension wire is required between the pipe and panel, verify it is connected with proper polarity, as shown on the wiring diagram. Failure to do so may result in an uncontrolled heater. Keep in mind that the "Red" wire is negative for thermocouples. Refer to the wiring diagram for the required wire type. The maximum loop resistance allowed is 100 ohms to avoid measurement error.

Wiring to the panel should be permanently installed in metallic or non-metallic electrical grade conduit in accordance with all applicable electrical codes, and should include a grounding conductor if non-metallic conduit is used.

Field supply wiring must be rated for 600Vac. Use copper conductors.

WARNING

Retighten all electrical connections that may have loosened during shipment. Failure to do so may result in damage to the Control Panel or risk of fire. The most critical are the power circuit conductors.

Confirm all unused conduit holes in the panel are sealed with plugs suitable for the environment.

Attach a ground conductor to the mounting lug provided, or by other appropriate means, per NEC Article 250.

Be sure the panel doors are properly closed and sealed to ensure personnel protection. Also, contaminants can create leakage, (shock) hazards, permanent damage, or failure to the Control Panel and should be avoided.

CAUTION

When performing Dielectric or Meg Ohm tests, remove transformer primary fusing to isolate control circuit electronic equipment. Failure to do so may result in damage to the control components.

If performing a dielectric test to confirm wiring insulation, test the power circuit at no more than two times the rated voltage plus 1000 volts after isolating the control transformer. If the control circuit is tested, pull out the process controller, remove secondary ground(s), and disconnect any High Limit Controllers. Test control circuit at 1200V max.

Impedance System Components

Transformer

It is important that the temperature in the area where the transformer is mounted does not exceed 104°F and that the air circulation is not impeded. The transformer should be reliably secured to the mounting surface. The transformer enclosure is rated NEMA Type 3R and is designed for outdoor use and provides a degree of protection against falling rain and sleet.

The correct location of the transformer relative to the system's pipe length is as follows:

Endfed Systems

When a single circuit hookup is used, the transformer can be located anywhere along the pipeline, but within the specified distance away from the pipe.

Midpoint Systems

When a midpoint hookup is used, the transformer must be located at the electrical midpoint of the length of pipe to be heated and within the specified distance away from the pipe.

Piping

Piping should be of continuous weld construction, fabricated according to applicable piping standards. Flanges should be used at branch connections and at heated section separations with isolator kits installed between as required.

Impedance heating produces the same even heat throughout the pipe, which will carry a low voltage current isolated from electrical grounds. To achieve this, each heating circuit must be the same electrically from end to end. At points where the heated line is connected to a tee, vessel or other line, either heated by another method or not requiring heat, the pipe must be electrically isolated using isolator kits, available from INDEECO. These should be located as close as possible to the tees or equipment to prevent any section of piping from being unheated. Pipe supports and hangers must also be electrically isolated from the impedance heated pipelines. Care must be taken at support points to insure that pipe expansion will not cause accidental grounding of the circuit.

Non-isolated valve handles and all other exposed metal parts on the pipeline that are electrically energized should be electrically insulated with glass tape and waterproofed.

The first thing to check, in case fuses are blown, is the piping. The areas where the piping could be grounded are usually at hanger and support points. Your preventive maintenance should include a periodic check of these points.

Terminal Plates

For locating the electrical midpoint on a midpoint connected circuit, a temporary connection can be made with a pipe clamp. The permanent connection can be made after the electrical midpoint has been determined. The plates should be welded to the piping to provide the best possible electrical connection between the pipe and the plate. All terminal plate welds are to be full circumferential welds. Remember that the location of the terminal plates defines the electrical circuit and plates should be located on flanges where available to provide the greatest length of heated pipe. High temperature applications may require the use of perforated plates in order to dissipate the heat before the cable connections are made. The terminal plate must have unobstructed air circulation to allow cooling.

Cable

Reference the wiring diagram for the proper hookup cable size. The cable is to be run in free air and strapped externally to the thermal insulation jacket, equally spaced around the circumference of the pipe and held in place every 6 to 9 feet, using aluminum or similar strap of non-ferrous material. The cable is not to be run in conduit, unless specified by INDEECO.

Cable Connections

The cable in the heating circuit is connected to the transformer and to each of the terminal plates. Care should be taken to insure the connectors are clean and free from foreign material before the connections are made. Wherever possible, the connections should be of the permanent type. Compression type cable lugs are recommended.

All mechanical cable connections should be checked periodically to see that they have not vibrated loose. Since impedance heating uses low voltage in the heating circuit, a

poor connection can be detrimental. The easiest check is to measure the temperature of the connection. If it is excessive, these connections should be taken apart and the mating surfaces cleaned and reassembled.

Thermal Insulation

Insulation jacketing shall be aluminum or other non-ferrous material. Otherwise, materials such as steel will induce a current through the jacket due to the magnetic field present. It is very important that insulation be properly installed for a weather-tight and reliable heating system. The aluminum jacket is to be trimmed back approximately 1/2" to prevent jacket from being electrically energized. The void created by trimming the jacket back is to be sealed with butyl rubber caulk to ensure a weather tight seal. At areas where insulation can be damaged, the insulation should be protected. Should the insulation become wet, broken or crushed, it should be repaired with materials like those used on the original installation. Wire or straps used to band insulation or the cables around the pipe shall be aluminum or other non-ferrous material.

Thermocouples

The thermocouple mounting pad should be welded to the pipe. The thermocouples should be located a minimum of five feet from any terminal plates, flanges, tees or any other item which may act as a heat sink and alter the temperature reading. On midpoint systems, one thermocouple should be installed on each side of the midpoint terminal plate connection a minimum of ten feet from the terminal plate.

It is recommended that minimum 16 AWG shielded and grounded thermocouple extension wire be used and installed in metallic conduit to eliminate possible false readings due to RFI or environmental conditions. It is essential that the correct type of thermocouple extension wire be used.

OPERATION

Cautions and Setup

CAUTION

Equipment should be operated by qualified personnel only to prevent equipment damage or failure.

Carefully review all instructions and become familiar with the equipment, safety interlocks, and process temperature controller provided before energizing the equipment.

DO NOT operate system at voltages in excess of that marked on the panel nameplate. Excess voltage can overload the power circuit components and wiring.

Temperature regulating devices and temperature limiting controls are recommended to control the heating process and safeguard the system from excessive temperatures that can cause damage. Also, damage to fluid could occur if the

pipe is allowed to exceed the maximum film temperature recommended by the manufacturer.

Ensure power ahead of the panel is off and perform the following steps:

1. Exercise all switches, circuit breakers and operating mechanisms to confirm they operate freely.
2. Conduct an insulation resistance test to ensure the system is free from short circuits or grounds.

INDEECO recommends that all safety interlocks be tested during initial startup to ensure they properly disable the system.

For solid state non-indicating controllers, it is recommended to dial the high limit controller setpoint down below the normal operating temperature either during initial startup operation or with only the control circuit on, and verify that

the contactor opens, disconnecting power to the transformer. Return the controller to the desired setpoint.

System Checkout

Check the primary voltage and compare with transformer design voltage.

Walk along the pipeline and look for obvious mechanical grounds on the piping, pipe supports and possible contact between the aluminum cover of the pipe insulation and protruding pipe supports, thermocouples, etc. Pipe insulation jacket seams should be down.

Check all thermocouples for a good contact between thermocouple and pipe surface (surface should be clean) and the correct hookup between the thermocouple and thermocouple extension wire. It is essential that the correct type of thermocouple extension wire be used. Reference wiring diagram for type of thermocouple wire to use. Keep in mind that the red wire is negative.

Make certain that all flange isolator kits are installed properly, all bolts to be in the same direction.

Check connections between terminal plates/angles and piping; the cross-sectional area of the welds should be at least equal to the cross-sectional area of the plate or angle.

Check all electrical connections for tightness.

Check for wet insulation. If there is wetness, some of the aluminum covering should be removed in order for the moisture to escape during heat up.

If a midpoint connection is used, measure to determine the correct midpoint location. When energized, the current readings to each end of the pipe should be within 5% of each other. **Uneven heating will occur, on either side of the connection, if the connection is not made at the actual electrical midpoint.**

Make certain that the return cable runs in free air, and is strapped externally to the thermal insulation, equally spaced around the circumference of the pipe.

Check to see that primary connections are made to the lowest voltage tap on the transformer.

Check panel fusing. Fuses should be dual element time delay class RK5 and rated for at least 125% of actual current draw.

Verify that all exposed metal parts on pipeline, such as valve handles and cable connections, that are energized are properly electrically insulated.

Initial Operation

Review the setup of the process controller. INDEECO factory-configures the controller inputs and outputs unless the user specifies a special controller.

Turn the Control Circuit Switch to the OFF position. Turn on power ahead of the panel and close panel main disconnect switch.

Connect primary lines from the control panel to the power transformer at the lowest voltage tap.

Turn the Control Circuit Switch to the ON position.

Inspect for alarm pilot lights. Push any red illuminated reset pilot lights to attempt resetting. All alarm lights should be reset.

Gradually increase the control setpoint and observe the system for proper operation.

Check the total secondary current. If the current reading is below the system design, change the tap selection progressively up until the proper current is reached.

Connect a temporary ground between X-1 of the transformer and structure. Measure the current flow through the ground wire. If the reading exceeds 1% of system current, reinspect the system for grounds.

Check the operation of all controlling instruments.

After the design temperature of the pipe has been reached, check the secondary current again and compare with the design current at that temperature.

Check again for grounds, which are possibly caused because of expansion of the piping.

Retighten all electrical connections and tighten again after a 24-hour period.

Adjust high limit temperature controllers by setting as close to the operating conditions as possible without nuisance tripping.

Shut Down

The heating system may be shut down by reducing the process setpoint to ambient. It is recommended to continue circulating the process fluid until temperatures are reduced to a safe temperature.

Turn the control circuit switch to OFF. Turn off main power disconnect switch.

Normal Operation

Turn on disconnect switch.

Adjust process controller to the desired setpoint.

Turn control circuit switch to ON.

Note: Be sure to use the Standby mode if the above steps cannot be accomplished quickly.

If the process temperature exceeds the high limit temperature controller's setpoint, the contactor will deenergize and shut off power to the transformer. The OVERTEMP pilot light will energize and the dry contact

across terminals A1/A2 will open for remote indication. When the process temperature has cooled down to a temperature below the controller's setpoint, press the manual reset pushbutton to reset the controller and the transformer will reenergize. The system should be investigated as to the cause of the overtemperature condition.

After any alarm condition, the system should be investigated and the problem remedied. Do not operate the equipment with safety devices disabled or serious damage to the system may result.

CONTROL METHODS

Control methods for electric heating systems can either be:

1. ON / OFF
2. Proportional, Integral, and Derivative (PID).

ON/OFF Systems

On/off systems utilize a process similar to a thermostat that operates a home furnace. A typical Control Panel is provided with a digital indicating process controller which accepts a thermocouple input from the process. The controller is configured to an SSR output to pull power contactors in and out, to cycle the load.

The process controller must be configured to limit the cycle rate to avoid quickly wearing out the power contactors. Contactors are typically rated for 100,000 cycles of operation.

Two methods can be used: "Hysteresis" or "Cycle Time".

Hysteresis defines a temperature range around the setpoint where the process controller will not change the state of the power contactor. A hysteresis value of 5°F would define the "error" or tolerance from setpoint that the user can accept. This is sometimes referred to as deadband. This method of control is typically recommended for ON/OFF impedance systems to prolong the life of the electrical components.

Cycle Time is a method to define the minimum time that the controller must wait between de-energizing and re-energizing the power contactor. A Cycle Time of 3-5 minutes on equipment operating continuously would wear out power contactors in about 2 years. If the Cycle Time is set for 3 minutes, but the temperature has not yet dropped below the setpoint, the heater will not come on until the temperature drops low enough.

PID Control

PID control utilizes Proportional, Integral, and Derivative control methods to scale the output from a process controller (typically 4-20mA) to an SCR Power Controller. Note that reverse acting signals are used with heating

systems where the system is OFF at 4mA and fully on at 20mA.

SCR Power Controllers are phase-angle fired units that linearly control, with respect to the process controller command signal, the RMS value of the load voltage.

For further details about PID control, refer to the process controller instruction manual.

Factors Impacting System Control

Many factors affect the setpoint tolerance and control of heating systems. Control Method (noted above), Heat Load Fluctuations, and Fluid Properties are all significant factors.

Heat Load Fluctuation, or changes in the process, can cause wide temperature fluctuations. Some typical changes to a heating process loop are:

1. Addition of fluid at a temperature below the process temperature
2. Opening or closing tank access covers
3. Starting or stopping fluid agitators
4. Ambient temperature changes
5. Fluid flow rate changes
6. Insulation thickness
7. Power available can be affected due to user voltage fluctuations

Fluid Thermal Properties can greatly impact temperature control. Fluids such as water, with high thermal conductivity, are easy to heat without experiencing large temperature gradients. Fluids such as wax or tar pitch have such low thermal conductivity that the system must be designed with a much lower pipe watt density than with most fluids. Solids buildup on the pipe wall can also reduce the heat transfer.

To obtain optimum control, the use of SCR control is recommended.

CAUTION

Troubleshooting and repairs should only be attempted by qualified maintenance personnel.

As opposed to alternative heating systems, Impedance Heating Systems are permanent. They are designed to provide effective heating of the pipe for as long as the pipe and/or process is installed. However, like any equipment, preventative maintenance is required.

Maintenance should be performed on an annual basis. This includes the equipment mounted to the pipe (terminal plates, secondary cables, etc.) as well as the transformer and control equipment.

Transformers and Pipeline Assembly

The transformer and pipeline assembly require periodic checks to ensure that all mechanical and electrical connections are tight and free of corrosion.

Take a voltage reading between the terminal plate and the copper conductor of the cable. Voltage drop should be less than .125 volt for each cable in parallel. Loose or corroded connectors create high resistance connections, system imbalances and possible system failures. If voltage drop is too high, replace compression lug.

Visually inspect the secondary cable insulation at the pipe connection. Excessive heat from the terminal plate, pipe or vessel will cause cracking and degradation of the cable insulation. Damaged cable should be replaced. Determine the cause of the excessive heat and rectify the problem by cleaning or replacing cable compression lugs, installing high temperature terminal plates, installing additional piping insulation or whatever is required to decrease the amount of heat at the cable connection.

Replace or thoroughly dry and clean any insulation that is damp or wet or shows an accumulation of deposited material from previous moisture. The performance of the heating system is dependent on the integrity of the thermal insulation system.

Visually inspect the entire piping system. Look for new equipment mounted to the pipe. Ensure pipe supports are properly installed and centered over the beams. Remove any external equipment that could cause grounding.

Verify and log power transformer primary tap connection, secondary voltage and current readings of each circuit. Compare the readings to original startup data or previous records for consistency. To insure the readings have a consistent basis, the readings should be taken when the system is operating at 100% output from the process controller.

Control Panel

WARNING

Hazard of electrical shock. Lock out and tag the branch circuit disconnect switch before working on the Control Panel.

Periodically check all electrical connections, including field and factory-made connections, for tightness, and all wiring for deterioration at least once a year or after any electrical fault. Inspect for signs of overheating, corrosion, or pitting of electrical joints. Dress up and clean all contact surfaces.

Exercise all switches, circuit breakers and operating mechanisms to confirm they operate freely, making sure that they quickly and securely throw the contacts fully open and fully closed. Wherever possible, check all devices for missing or broken parts, proper spring tension, free movement, rusting or corrosion, dirt, and excessive wear. Adjust, clean, lubricate and/or replace parts as required.

Inspect the enclosure and conduit connections for evidence of water leaks or moisture collection. Tighten connections as required. Do not continue using a panel with signs of damage.

Clean any appreciable accumulation of dust and dirt. Attempt to seal source of dust entry.

Check fuses to make sure they have the proper ampere rating and interrupting rating. Make sure that non-current-limiting fuses are never used as replacements for current-limiting fuses. Never attempt to defeat rejection mechanisms that are provided to prevent the installation of the wrong type of fuses. Fuses should be dual element time delay Class RK5.

Check insulation resistance:

- If a severe electrical fault has occurred.
- If it has been necessary to replace parts or clean insulating surfaces.

Replacement parts must be of equal or higher ratings. Contact the factory for recommended spare parts.

TROUBLESHOOTING

CAUTION

Troubleshooting and repair should only be attempted by qualified maintenance personnel.

Your Impedance Heating System has been designed as a simple series or parallel circuit. When the system is initially installed and operating, there should be little or no downtime due to malfunction.

GENERAL TROUBLESHOOTING GUIDE

PROBLEM	CAUSE	SOLUTION
<ul style="list-style-type: none"> ◦ Process temperature is below setpoint. 	<ul style="list-style-type: none"> ◦ Proper heat up time has not been allowed. ◦ Additional piping has been added to the system. ◦ Temperature controller is not set to proper temperature. ◦ High limit controller has tripped. ◦ Low line voltage. ◦ Insufficient insulation. 	<ul style="list-style-type: none"> ◦ Verify heat up/recovery time for system. ◦ Isolate all additional piping using isolator kits as required. ◦ Verify setpoint. Check controller output LED to verify status. ◦ Allow system to cool and reset high limit. ◦ Confirm supply power is no more than 3% low. ◦ Insulate exposed piping to reduce losses.
<ul style="list-style-type: none"> ◦ Panel will not energize. 	<ul style="list-style-type: none"> ◦ No power to panel. ◦ Disconnect switch is not turned on. ◦ Control circuit fusing is blown. ◦ Remote interlock is open. ◦ Component failure. 	<ul style="list-style-type: none"> ◦ Supply power. ◦ Turn disconnect switch to the ON position. ◦ Check and replace fusing if necessary. ◦ Close remote interlock. ◦ Check and replace component if required.
<ul style="list-style-type: none"> ◦ System does not energize. 	<ul style="list-style-type: none"> ◦ High limit controller has tripped. ◦ Interconnecting wire between panel and impedance transformer is broken or connection is loose. ◦ Power fusing is blown. ◦ Component failure. 	<ul style="list-style-type: none"> ◦ Allow system to cool and reset high limit. ◦ Check wire continuity and repair if necessary. ◦ Check and replace fusing if necessary. ◦ Confirm supply power is no more than 7% high. ◦ Check and replace component if necessary.
<ul style="list-style-type: none"> ◦ Pilot light not operating when system is operating correctly. 	<ul style="list-style-type: none"> ◦ Bulb burnt out. 	<ul style="list-style-type: none"> ◦ Replace bulb.
<ul style="list-style-type: none"> ◦ Nuisance over-temperature tripping. 	<ul style="list-style-type: none"> ◦ High limit setpoint temperature too low. 	<ul style="list-style-type: none"> ◦ Consult this manual for the proper setpoint.

IF PROBLEM PERSISTS, PLEASE CONSULT FACTORY.

HAZARDOUS AREAS

(where applicable)

WARNING – Explosion Hazard

INDEECO strongly recommends installation be performed by qualified personnel familiar with the National Electrical Code and all local codes and standards regarding explosion-proof equipment. It is the responsibility of the installer to verify the safety and suitability of the installation.

Per Article 500-516 of the National Electrical Code, a hazardous area is defined by a “Class”, “Division”, “Group”, and “Temperature Code”. The Class can be I or II, where Class I indicates that the hazard classification is due to the presence of an explosive vapor. Class II indicates an explosive dust. The Division can be either 1 or 2. Division 1 indicates a hazard is ALWAYS considered to be present. Division 2 means the hazard is only present under abnormal conditions. The Group defines the explosiveness of the hazard. The Temperature Code specifies the temperature at which a hazard will ignite.

INDEECO can provide Impedance Heating designs suitable for Class I or II, **Division 2 locations only**. A panel should never be placed in an environment not noted on the nameplate.

NEVER operate the panel in an atmosphere with an ignition code temperature LOWER THAN the nameplate rating. The user must determine the actual area classification.

Special design considerations for impedance systems and panels used in hazardous locations:

1. Locate all electrical connections in an appropriate enclosure.
2. Prevent surface temperatures of the heater from exceeding the design ignition temperature.
3. All “live” components of the impedance system, including the pipe and flanges, must be covered or protected from accidental contact which may draw an arc to ground and create a spark.

INDEECO Control Panels designed for hazardous locations are typically provided with a purged enclosure. Nitrogen or other inert gas must be supplied to the purge unit from a constant supply. Cast aluminum enclosures can also be provided. The control panel may be located out of the hazardous area to eliminate the need for a purged or cast aluminum enclosure.

All conduits entering the panel must be sealed within 18” of the heater using an explosion-proof conduit seal. Any unused openings must be properly sealed with a steel pipe plug or rated cover. Follow the NEC for specific conduit requirements such as the requirement for Rigid Conduit.

To ensure proper flamepath, all threaded conduits must use rated fittings and be tight with a minimum of 5 good threads engaged. Any machined metal-to-metal surfaces on terminal boxes must be handled carefully to prevent scratches which may void the explosion-proof rating.

WARNING - Risk of Explosion

Operating the system at a voltage higher than the nameplate value may result in elevated temperatures and amperage above the design ratings.

Proper grounding of equipment in hazardous areas is critical to eliminate potential sources of sparking.

Replacement of electrical components should only be done by authorized personnel familiar with the requirements of maintaining electrical equipment in an explosion-hazard area.

Typical Impedance Pipeline Heating System

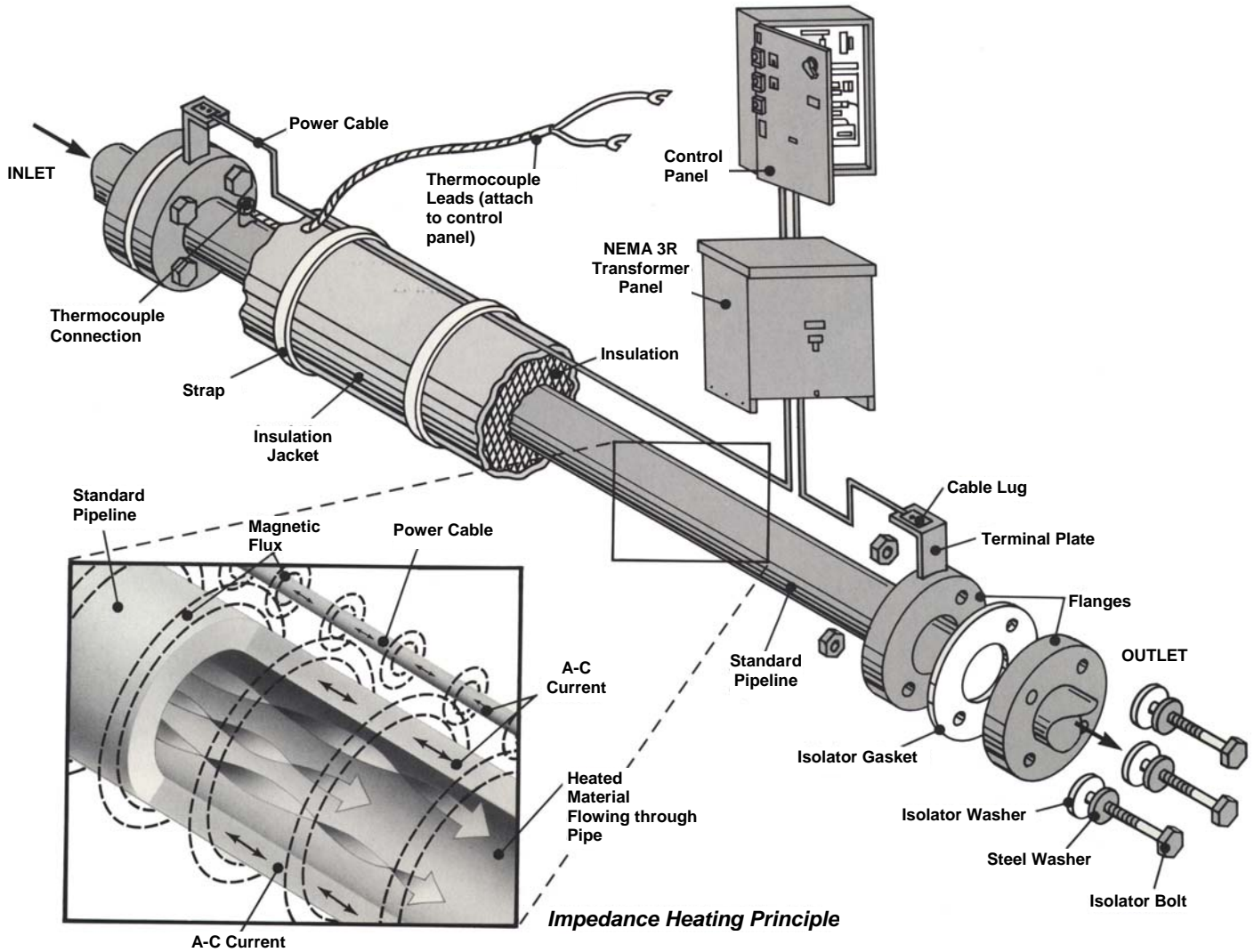

INDEECO
 425 Hanley Industrial Court
 St. Louis, MO 63144
 Phone: (314) 644-4300 Fax: (314) 644-5332
 www.indeeco.com