

Mounting Holes: Power Controllers and Input Board

Note: Use 0.250" clearance holes to mount the power controller to the side panel with #8-32 machine screws.

Note: Mount the board to the panel with #8 sheet metal screws and spacers.

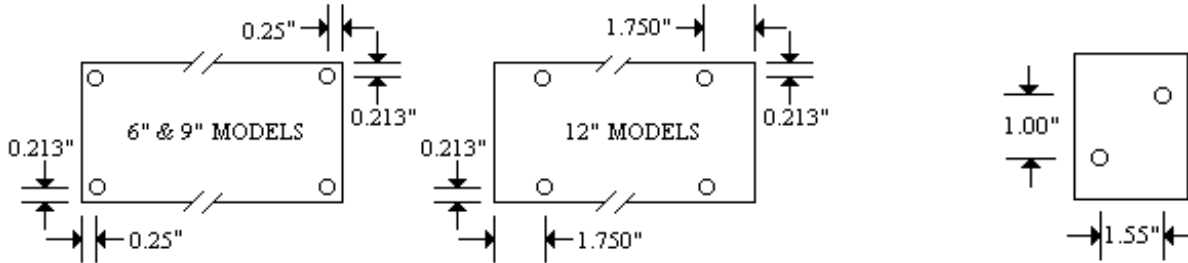

Wiring Diagrams: 1 Phase & 3 Phase Power Controllers with Input Board

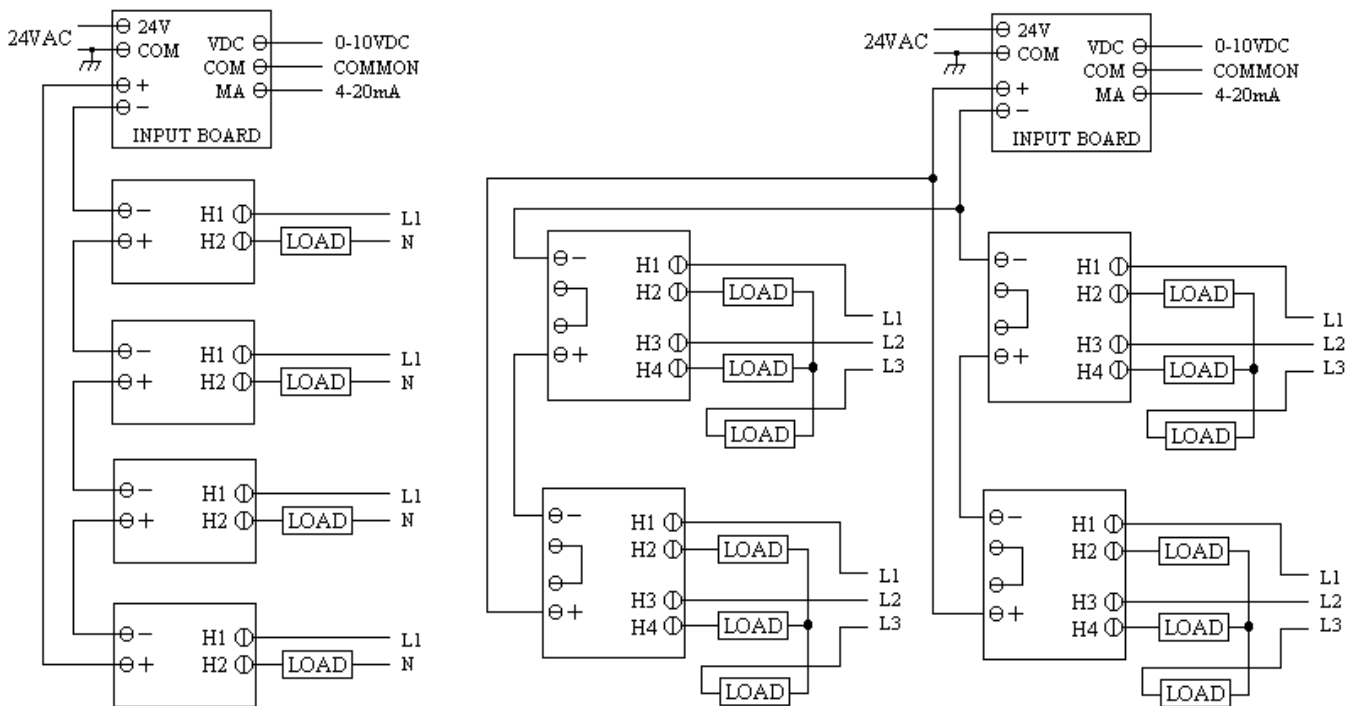

INDECO
 425 Hanley Industrial Ct.
 St. Louis, MO 63144
 314-644-4300
www.indeco.com