

electric heating and controls

commercial heating equipment

Duct Heaters

UL Listed and CSA Approved self-contained electric duct heaters. Standard and custom slip-in, flanged and patented slip-and-drive mountings are available. Wide selection of frame sizes, KW ratings, required safety devices and electronic controls built in as part of a standard package. INDEECO offers a full line of open coil and finned tubular designs for air handling equipment. INDEECO also manufactures floor heaters, HVAC heaters and cab heaters for the railcar industry.

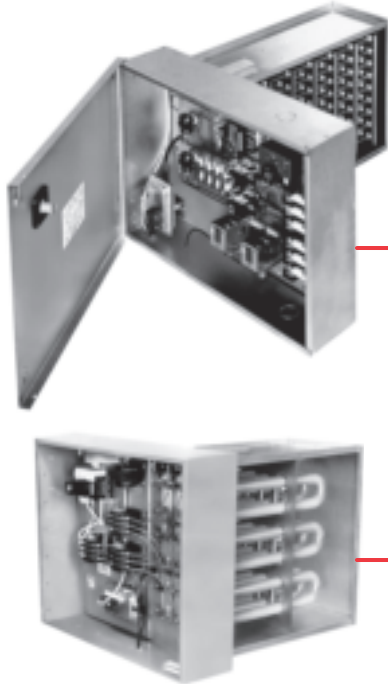

Open Coil Duct Heaters

- Suitable for most standard HVAC ducted systems.
- Over 30 million Type QUA-Slip-In and QUZ-Flanged designs available for 72 hour shipment.
- High quality grade A nickel-chromium heating element wire.
- Heavy gauge sheet metal frame and enclosure.

Finned Tubular Duct Heaters

- Used in demanding applications; wet, dirty or dusty locations.
- Stainless steel elements are standard with all finned tubular duct heaters.
- Rugged construction eliminates hazard of electric shock.
- Stainless steel heater frame and terminal enclosure available for wet corrosive applications.



Marine Duty Duct Heaters

- Complete control packages standard.
- Construction I/A/W 46 CFR, part 111.87 is available.
- Flange (standard) or slip-in mounting available at no extra charge.
- UL and ABS Approved.
- Heavy duty construction for shipboard use.
- Custom sizes available.



Mil-Spec Duct Heaters

- MIL-H-22594A (SH) compliance for all sizes.
- Support for all current and many previous Mil-Spec sizes.
- NSN and APL (CID) numbers available.
- Compliance with MIL-PRF-22594-B.

commercial heating equipment

TRIAD® Wash Down and Corrosion Resistant Unit Heaters

- Stainless steel construction with nonmetallic NEMA 4X enclosure which houses the element terminals and built-in controls.
- Comes complete with a stainless steel bracket that can be used for wall or ceiling mounting.
- Single-point connection for all standard voltages up to 600 VAC, 3-phase, 60 Hz.
- Ratings up to 47 kW.
- UL/cUL Listed and ABS Approved.



Industrial Unit Heaters

- Units feature stainless steel finned tubular heating elements, built-in controls, adjustable discharge louvers and bracket for ceiling or wall mounting.
- Ratings up to 38 kW.
- High CFM capacities and throws up to 50 feet available.
- cUL_{US} Listed.



Comfort Heating Products

Wide range of products for both commercial and industrial applications. A full line of built-in controls and remote thermostats are available with these products to complete the package.

Forced-Air Heaters

- Cabinet unit heaters range from 2,000 to 24,000 watts. Units may be mounted on the floor, wall or ceiling, and can be recessed for wall or ceiling applications. Full line of optional features available.
- Commercial and architectural wall heaters available from 2,000 to 12,000 watts.
- Heavy-duty commercial unit heaters, offered to 60 kW, can be mounted horizontally or vertically. Each heater is furnished with both ceiling and wall mounting brackets for easy installation.
- Ceiling heaters for surface, T-Bar or recessed mounting with voltage up to 480 VAC, 3-phase and up to 10,000 watts.

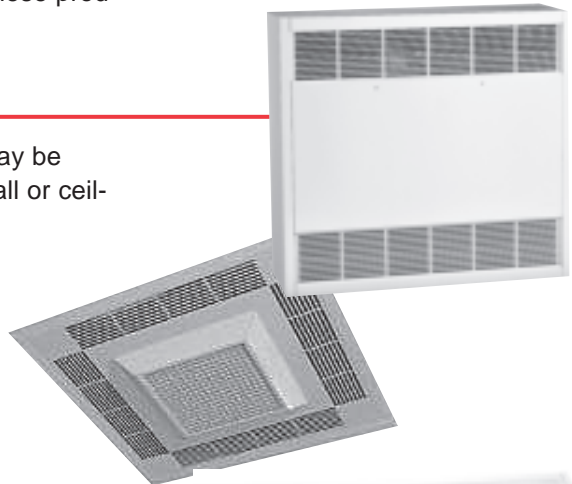

Baseboard Heaters

- Heavy-duty baseboard heaters for commercial, architectural or industrial applications. Available in flat or sloped top design with a durable epoxy/polyester powder paint finish on a heavy gauge aluminum and steel cabinet. Sizes range from 300 to 4,000 watts.
- Architectural convectors provide large amounts of heat without the fan noise associated with unit heaters. Can be floor or wall mounted, and fully recessed with a front warm air outlet.



commercial heating equipment



Explosion-proof Duct Heaters

- Three Designs: Ultra-Safe™ Series, EP2 and Custom with ratings up to 750 kW, 600 VAC to meet NEC Divisions 1 & 2 locations.
- Custom built to fit new or existing systems.
- Standard flanged or optional slip-in construction available.
- SCR control.
- Ultra-Safe™ designs are Factory Mutual (FM), CSA Approval for Classes I & II Divisions, 1 & 2, Groups B, C, D, F & G, temperature code T3C 320°F (160° C).

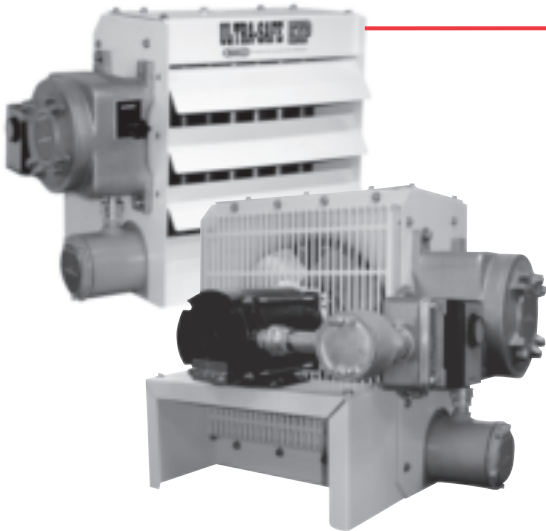

Explosion-proof Unit Heaters

- ULTRA-SAFE™ EXP has the industry's lowest ignition temperature code rating of T3C.
- Classes I & II, Divisions 1 & 2, Groups C, D, E, F & G.
- Built-in controls.
- Small, economical COMPACT designs up to 12 kW.
- Factory Mutual (FM), CSA, ABS Approved.
- ULTRA-SAFE™ EXP with the industries lowest ignition temperature code rating of T3C for Classes I & II, Divisions 1 & 2, Groups C, D, E, F & G, Factory Mutual (FM) and CSA Approved. 316 SS and Herestie® corrosion-resistant constructions are available. With cataloged listing up to 30 kW, 600 VAC, 3-phase, 50/60 Hz with single point electrical connection.
- Small economical COMPACT unit heater for Class I, Divisions 1 and 2, Group D, with Factory Mutual (FM), CSA and ABS Approvals. STAINLESS STEEL corrosion-resistant is standard with optional dirty-duty construction is available. Ratings up to 12 kW, 600 VAC, 3-phase.

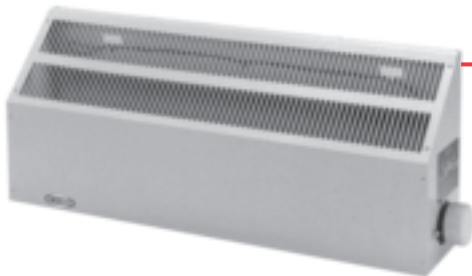

Explosion-proof Convection Heaters

- Class I & II, Divisions 1 & 2, Groups B, C, D, E, F & G.
- Ratings from 500 to 9,500 watts.
- Sloped-top cabinet design.
- Available with built-in controls.
- NEMA 3 construction for wet locations is available.
- Factory Mutual (FM), CSA, ABS Approved.

industrial heating equipment

Tubular & Finned Tubular Elements

- Flexible application possibilities.
- Tubular applications: Clamp-on, wrap-around, immersion, convection or radiant heating.
- Finned tubular applications: Natural convection or forced draft space heating, industrial process air heating, preheat & reheat.
- Custom designs to fit the job.
- 8 sheath materials available.
- Options: 16 different terminations, insulators and seals, special fittings and mounting plates.
- UL and CSA Recognized, CE self certification.
- Hermetically sealed mil spec elements, qualified to MIL-H-22594A.



Immersion Heaters

INDEECO offers a wide variety of designs for heating gases, liquids and soft metals by direct immersion. Standard units in copper, steel, stainless and Incoloy; custom units in 8 different sheath materials, liquidproof or explosion-resistant terminal boxes, hermetic terminal end seals, high temperature construction and built-in controls. UL Listed and CSA Approved designs are available.

- Pipe Thread Heaters.
- Pipe Flange Heaters - 2 - 24" ANSI Flanges to 1500 lbs.
- Over-the-Side Heaters.
- Cooling Tower Heaters.
- Bottom Mounted Heaters.
- Tank Heaters.
- CSA listed pipe thread for hazardous areas.



industrial heating equipment



Circulation Heaters

Designed to heat liquids, gases or vapors; including air, heat transfer fluids, helium, nitrogen, oils, steam and water.

- For outlet temperatures up to 1200°F.
- Standard design includes heavy wall steel vessel (insulated and jacketed) and factory-mounted thermostat.
- Options: Stainless steel, weatherproof, explosion-resistant and ASME constructions; special vessel and heater materials.
- Remote panels sequencer or SCR control in NEMA 12, NEMA 4, NEMA 4X or NEMA 7 enclosures.



Process Air Heaters

Designed for use in ovens, autoclaves and other industrial forced air systems for drying, baking or heat treating.

- For outlet air temperature up to 1200° F.
- Open coil, tubular and finned tubular designs.
- Standard ratings up to 4,300 kW; custom applications to 12,000 kW.
- Options: Pressure tight, pressure plates, angle iron frames, and control systems.
- Remote panels sequencer or SCR control in NEMA 12, NEMA 4, NEMA 4X or NEMA 7 enclosures.

industrial heating equipment

Storage Tank Heating Systems

Used to raise or maintain temperatures to 1000° F for a wide variety of liquids and gases found in storage tanks and process vessels. Low watt density open coil elements recommended for heating viscous and temperature sensitive materials including asphalt, chocolate, fuel oils, pitch, resins and tar.

- Storage Tank Heaters with built-in controls.
- Railroad Tank Car Heaters for restoring heat lost during transit.
- Pipe insert heaters for installation in custom supplied 3" schedule 40 wells.

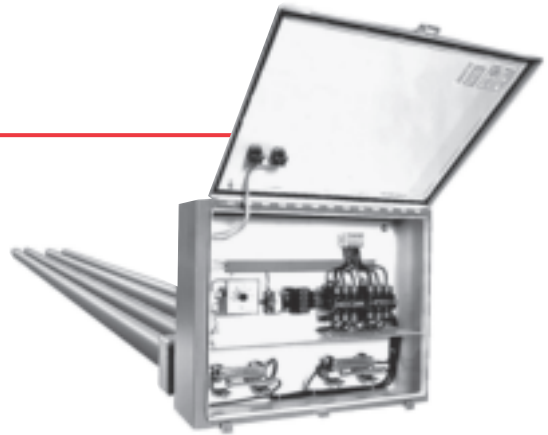

Impedance Pipeline Heating Systems

- The pipe becomes the heating element, eliminating heater burnout common with heat tracing and other maintenance problems.
- Provides uniform heating for viscous materials so there are no hot spots.
- Used to heat asphalt, chocolate, glue, molasses, paraffin, syrups, tar, and wax.
- Used to heat air and other gases up to 1600° F.
- INDEECO provides single source responsibility for design, hardware, and start-up assistance.
- Hardware includes control panel, system transformer, thermocouple sensor, electrical terminations, and isolation kits, as required.



Heater Control Panels

INDEECO provides total system responsibility with control systems engineered to match INDEECO heating equipment.

- Full proportioned SCR system with PID temperature control.
- Control Panel enclosures available to meet NEMA 1, 4, 4X, 7, and 12 standards for indoor or outdoor locations, hazardous or non-hazardous areas.
- All components are factory mounted and wired in compliance with NEC.
- UL Listed.
- RS485 communication, 1/16 DIN manual over temperature controller with reset are available options.
- The Quick Ship Temperature Control panel provides fast shipment, precise temperature control, compact packaging, and is pre-engineered for resistive load applications. The panel is completely assembled, pre-wired, tested, and ready for trouble-free installation and operation.



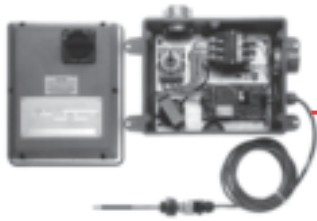

Electronic Controls

Our controls division has over 30 years of experience in designing and manufacturing standard and custom electronic controls for industrial and commercial applications.

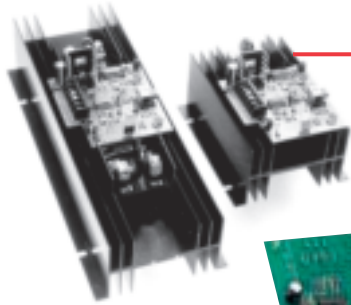

SCR Power Controllers

- Ratings from 10 to 200 amps, 120 to 600 volts.
- Zero cross-fired.
- NEMA 4 and 4X rated designs available.
- Most models UL or UL/CSA Recognized.

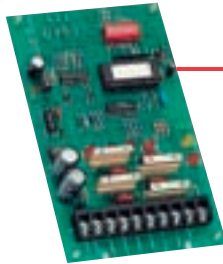

Electronic Sequencers

- Microprocessor-based step control of up to 20 stages.
- Proportional, dead band or “vernier” control.
- Linear or progressive sequencing.
- All models UL Recognized.



Temperature/Process Controls



- “On/Off”, Proportional and PID controls.
- Fuzzy logic, ramp-and-soak and RS-485 interfaces available.
- Combination temperature/liquid level controls.
- Multi-channel controls up to 4 channels.
- Room and duct thermostats for space heating applications including UL Listed designs for wet, corrosive and hazardous areas.
- Bulb and capillary thermostats for industrial process heating applications.
- Accessories include pilot lights, contactors, pipe thread connectors and special enclosures.



INDUSTRIAL ENGINEERING & EQUIPMENT CO.
 425 HANLEY INDUSTRIAL COURT
 ST. LOUIS, MO 63144
 314-644-4300
 FAX: 314-644-5332
www.indeeco.com

FOR YOUR NEAREST INDEECO REPRESENTATIVE CALL: